

T.C.
MARMARA UNIVERSITY
INSTITUTE FOR GRADUATE STUDIES IN
PURE AND APPLIED SCIENCES

DESIGN AND OPERATION OF A LABORATORY SCALE
FLUIDIZED BED GASIFICATION SYSTEM

Ufuk KAYAHAN

THESIS
FOR THE DEGREE OF MASTER OF SCIENCE
IN
MECHANICAL ENGINEERING

SUPERVISOR
Prof. Dr. Z. Sibel ÖZDOĞAN

İSTANBUL 2008

T.C.
MARMARA UNIVERSITY
INSTITUTE FOR GRADUATE STUDIES IN
PURE AND APPLIED SCIENCES

DESIGN AND OPERATION OF A LABORATORY SCALE
FLUIDIZED BED GASIFICATION SYSTEM

Ufuk KAYAHAN
141101820050007

THESIS
FOR THE DEGREE OF MASTER OF SCIENCE
IN
MECHANICAL ENGINEERING

SUPERVISOR
Prof. Dr. Z. Sibel ÖZDOĞAN

İSTANBUL 2008

ACKNOWLEDGEMENT

I would like to express my gratitude to all those who gave me the possibility to complete this thesis.

I am deeply indebted to my supervisor Prof. Dr. Z. Sibel Özdoğan whose stimulating suggestions and encouragement helped me all the time of research for writing this thesis.

I want to thank the Management of TUBITAK-MRC Energy Institute and I'm also grateful to Assoc. Prof. Hayati Olgun for giving me permission to commence this thesis in the first instance, to do the necessary research work and to use departmental facilities.

I would like to give my special thanks to Serhat Gül, Güzide Yinesor, Enver İnce, Mario Dias and other colleagues from TUBITAK-MRC for all their help, support, interest and valuable hints.

I also want to thank my father, mother and sister for their spiritual support.

Especially, I would like to give my special thanks to my wife Fatma whose patient love enabled me to complete this work.

June 2008

Ufuk KAYAHAN

CONTENTS

| | PAGE |
|--|------------|
| ACKNOWLEDGEMENT | i |
| CONTENTS | ii |
| ÖZET | vi |
| ABSTRACT | vii |
| SYMBOLS | x |
| ABBREVIATIONS | xi |
| FIGURES | xii |
| TABLES | xiv |
| CHAPTER I. INTRODUCTION AND AIM | 1 |
| CHAPTER II. GENERAL BACKGROUND | 5 |
| II. 1. HISTORICAL PERSPECTIVE | 5 |
| II. 2. LITERATURE SURVEY | 7 |
| II. 3. APPLICATIONS | 10 |
| II. 4. CHEMISTRY OF GASIFICATION | 11 |
| II. 4. 1. Drying | 12 |
| II. 4. 2. Pyrolysis | 12 |
| II. 4. 3. Combustion | 12 |
| II. 4. 4. Reduction | 13 |
| II. 4. 4. 1. Water-Gas Reaction | 13 |
| II. 4. 4. 2. Boudouard Reaction | 14 |
| II. 4. 4. 3. Shift Reaction | 14 |
| II. 4. 4. 4. Methanation | 14 |
| II. 5. ADVANTAGES OF GASIFICATION | 14 |
| II. 6. OPERATING PARAMETERS OF GASIFICATION | 15 |
| II. 6. 1. Fuel Characteristic | 16 |

| | |
|---|-----------|
| II. 6. 1. 1. Fuel reactivity | 16 |
| II. 6. 1. 2. Moisture Content | 16 |
| II. 6. 1. 3. Ash Content | 17 |
| II. 6. 1. 4. Volatile matter | 17 |
| II. 6. 2. Temperature | 17 |
| II. 6. 3. Particle Size | 17 |
| II. 6. 4 Operating Pressure..... | 17 |
| II. 6. 5. Gasification agent | 18 |
| II. 6. 6. Equivalence Ratio | 18 |
| II. 7. TYPES OF GASIFIERS..... | 18 |
| II. 7. 1. Entrained Bed Gasifier..... | 18 |
| II. 7. 2. Fixed Bed Gasifier | 19 |
| II. 7. 2. 1. Updraft Gasifier | 19 |
| II. 7. 2. 2. Downdraft Gasifier..... | 20 |
| II. 7. 2. 3. Cross-Draft Gasifier | 21 |
| II. 7. 3. Fluidized Bed Gasifier | 21 |
| II. 7. 3. 1. Bubbling Fluidized Bed Gasifier..... | 23 |
| II. 7. 3. 2. Circulating Fluidized Bed Gasifiers..... | 23 |
| II. 7. 4. Comparison of Fixed Bed and Fluidized Bed Gasifiers | 24 |
| II. 8. CHARACTERISTICS OF SOLID PARTICLES..... | 25 |
| II. 8. 1. Particle Size Measurement. | 25 |
| II. 8. 2. Sphericity | 25 |
| II. 8. 3. Voidage..... | 26 |
| II. 8. 4. Particle Classification | 26 |
| II. 8. 4. 1. Group C..... | 27 |
| II. 8. 4. 1. Group A..... | 27 |
| II. 8. 4. 2. Group B | 27 |
| II. 8. 4. 3. Group D..... | 27 |
| II. 9. FLUIDIZATION PHENOMENA..... | 27 |

| | |
|---|-----------|
| II. 8. 1. Packed Bed | 29 |
| II. 8. 2. Bubbling Fluidized Bed | 29 |
| III. METHODOLOGY | 32 |
| III. 1. GASIFIER DESIGN..... | 34 |
| III. 1. 1. Selection and Analyses of fuels..... | 34 |
| III. 1. 1. 1. Proximate Analysis | 34 |
| III. 1. 1. 2. Ultimate Analysis | 35 |
| III. 1. 1. 3. Heating Value | 35 |
| III. 1. 2. Stoichiometric Air Need For Combustion..... | 35 |
| III. 1. 3. Selection of ER for Gasification..... | 36 |
| III. 1. 4. Fluidization Velocity..... | 37 |
| III. 1. 5. Reactor Cross Sectional Area and The Height | 37 |
| III. 2. DISTRIBUTOR PLATE DESIGN | 37 |
| III. 3. SCREW FEEDER DESIGN | 39 |
| III. 4. CYCLONE DESIGN | 41 |
| III. 5. EXCEL PROGRAM..... | 42 |
| III. 6. MANUFACTURING OF THE SYSTEM | 46 |
| III. 7. COLD FLUIDIZED BED MODEL AND ANCILLARIES | 47 |
| III. 8. GASIFICATION SYSTEM AND ITS ANCILLARIES | 48 |
| III. 9. EXPERIMENTAL WORK | 50 |
| III. 9. 1. Start-up..... | 51 |
| III. 9. 2. Experiment..... | 51 |
| III. 9. 3. Shut down | 52 |
| III. 9. 4. Post Experiment | 52 |
| IV. RESULTS AND DISCUSSIONS..... | 53 |
| IV. 1. COLD MODEL EXPERIMENTAL RESULT | 53 |
| IV. 2. GASIFIER DESIGN CACLULATIONS | 55 |
| IV. 2. 1. Selection and Analyses of fuel | 55 |
| IV. 2. 2. Stiochiometric Air Need for Combustion..... | 56 |

| | |
|---|----|
| IV. 2. 3. Selection of ER For Gasification | 56 |
| IV. 2. 4. Fluidization Velocity..... | 57 |
| IV. 2. 5. Reactor Cross Sectional Area and The Height | 58 |
| IV. 3. DISTRIBUTOR PLATE DESIGN | 58 |
| IV. 4. SCREW FEEDER DESIGN..... | 59 |
| IV. 5. CYCLONE DESGIN | 61 |
| IV.6. EXPERIMENTAL MATRIX | 63 |
| IV.7 RESULTS OF OLIVE CAKE EXPERIMENTS | 63 |
| IV. 8. RESULTS OF ORHANELI COAL EXPERIMENTS | 70 |
| V. CONCLUDING REMARKS AND SUGGESTIONS..... | 74 |
| REFERENCES..... | 76 |
| APPENDIX | 79 |
| CURRICULUM VITAE..... | 85 |

ÖZET

LABORATUVAR ÖLÇEKLİ AKIŞKAN YATAK GAZLAŞTIRMA SİSTEMİNİN TASARIMI VE ÇALIŞTIRILMASI

Türkiye ihtiyacı olan elektriğin %70'ini ithal etmektedir. Bu nedenle ülkemizin kendi kaynakları olan biokütle ve kömürün enerji üretiminde kullanımının artırılması çok önemlidir. Ancak Türk linyitlerinin nem, kükürt ve kül miktarları yüksek olduğundan kalitesi çok düşüktür. Linyitlerin %66.3'ü 1000-2000 kcal/kg arasında ısıl değere sahiptir. Biokütlede ise kükürt ve kül miktarları daha düşüktür.

Gazlaştırma karbon içerikli malzemelerin yanabilir gazlara dönüştüğü termal bir çevirim yöntemidir. Gazlaştırma teknolojisi temiz ve verimli bir enerji üretim teknolojisidir. Biokütle veya kömür bir besleyici yardımıyla gazlaştırıcı reaktöre beslenir. Aynı zamanda hesaplanan kadar hava da sisteme gönderilir. Reaksiyonlar yüksek sıcaklıklarda gerçekleşir (800-900°C). Beslenen havanın hesaplanan stokiometrik havaya oranı hava fazlalık katsayısı olarak adlandırılır ve genellikle 0,2 ile 0,4 arasında değişir. Hava fazlalık katsayısı gazlaştırma için önemli bir parametredir. Diğer önemli bir parametre ise çalışma sıcaklığıdır.

Akışkan yatak teknolojisi akışkanlaşma prensibini kullanır. Buna göre 1-2mm büyüklüğünde yakıtlar reaktörün içine gönderilir. Reaktörün yatağında 100-600 micron büyüklüğünde parçacıklar bulunmaktadır. Bu parçacıkların içinden yukarı doğru hava geçirilir. Bu hava reaktörün altından girer ve bir dağıtıcı plaka yardımıyla düzgün bir şekilde dağıtılır. Kumların arasından geçen hava belirli bir değere ulaştığında kumlar hava asılı kalmaya başlar. Bu akışkanlaşma olarak adlandırılır. İçeride oluşan türbulant ortam yakıtlar ve sıcak parçacıklar arasında güzel bir karışım oluşturur bu da yüksek ısı transfer katsayıları elde etmemizi sağlar.

Bu tez kapsamında bir soğuk akışkan yatak modeli ile bir kabarcıklı akışkan yatak gazlaştırıcı tasarlanmış ve imal edilmiştir. Tasarım adımları ayrıntılı olarak anlatılmıştır. Soğuk modelde 282 mikron çapındaki silika kumun minimum akışkanlaşma hızı deneysel olarak bulunmuştur. Kabarcıklı akışkan yatak gazlaştırıcıda Orhaneli kömürü ve pirina ile deneyler yapılmıştır. Bu deneylerde

gazlaştırma parametreleri olan sıcaklık ve hava fazlalık katsayısı deęiştirilerek yüksek ısıl deęerlikli gaz ürün elde edilmeye çalışılmıştır. Deneyler sonucunda Orhaneli kömürü için en iyi gazlaştırma koşullarının 850°C sıcaklık ve 0,35 hava fazlalık katsayında; Prina için en iyi koşulların ise 850°C ve 0,30 hava fazlalık katsayısında sağlandığı görülmüştür.

Anahtar Kelimeler: Gazlaştırma, Akışkan yatak, Hava fazlalık katsayısı Sıcaklık.

Haziran-2008

Ufuk KAYAHAN

ABSTRACT

DESIGN AND OPERATION OF A LABORATORY SCALE FLUIDISED BED GASIFICATION SYSTEM

Turkey is importing 70% of its energy. It is very important for Turkey to increase the usage of the produced biomass and coal in terms of clean energy production. Turkish coals are generally characterized by their high moisture, sulfur and ash content. %66.3 of Turkish coals have between 1000-2000 Kcal/kg calorific value. In contrast biomass resources in general have much lower sulfur and ash contents.

Gasification is the thermal conversion of the carbonaceous materials to combustible gas. The technology enables the production of synthetic gas from low value carbon-based feedstock such as coal, and biomass. The biomass or coal is fed to a reactor by a feeder. The calculated amount of air is also introduced to the reactor. Reactions occur at high temperatures. The ratio of the feeding air to the stiochiometric air is called Equivalence ratio which generally differs between 0,2-0,4. ER is very important operation parameter. Another important operation parameter for gasification is temperature which is usually between 800-900C for fluidized bed gasifiers.

Fluidized Bed technology utilizes the fluidization principle in which crushed (1 –3 mm size) fuel is injected into the reactor. Air enters to the bottom of the reactor through air distribution nozzles where fine particles (100-600 micron) are placed. When air velocity reached a certain value particles are suspended in the bed this is called fluidization. Turbulent ambient inside the reactor results great mixing of hot particles and fuel, enabling high heat transfer.

Within the scope of this thesis cold fluidized bed model and bubbling fluidized bed gasifier were designed and built. All design steps were explained in detail. Minimum fluidization velocity was found experimentally for 282 micron silica sand with cold model. Olive cake and Orhaneli coal were gasified with bubbling fluidized bed gasifier. Gasification parameters Temperature and Equivalence ratio were tried to optimize to get high calorific value gas. The results show that the highest calorific

value is achieved at 850°C 0,3 ER for Olive Cake and at 850°C 0,35 ER for Orhaneli coal

Key words. Gasification, Fluidized Bed, Equivalence Ratio, Temperature,

June-2008

Ufuk KAYAHAN

SYMBOLS

| | |
|-----------------------------------|--|
| A | : Area (m ²) |
| D_m | : Mean particle diameter (micron) |
| D_p | : Pitch diameter (mm) |
| D_s | : Shaft diameter (mm) |
| \dot{m}_{air} | : Mass air flow rate (kg/h) |
| N | : Number of orifice |
| ΔP | : Pressure drop (kpa) |
| P | : Pitch (mm) |
| Q_{air} | : Volumetric air flow rate (m ³ /h) |
| t | : Zaman (s) |
| T | : Sıcaklık (°C) |
| U_{mf} | : Min. fluidizaion velocity (m/s) |
| U_o | : Operation velocity (m/s) |
| V_a | : Axial velocity (m/s) |
| V_t | : Tangential Velocity (m/s) |
| Ø | : Sphericity |
| ρ_g | : Density of fluid (kg/m ³) |
| ϵ | : Void fraction |
| μ | : Viscosity |

ABBREVIATIONS

BFB : Bubbling Fluidized Bed

CFB : Circulating Fluidized Bed

F-T : Fischer-Tropsch

ER : Equivalence Ratio

HHV : Higher Heating Value

IGCC : Integrated Gasification Combined-Cycle

LHV : Lower Heating Value

Mtoe : Millon Tonne of Oil Equivalent

PAH : Polyaromatic hydrocarbons

RPM : Revolution per minute

Syngas: Synthetic Gas

TKI : General Directorate of Turkish Coal

FIGURES

| | <u>PAGE</u> |
|---|-------------|
| Figure I.1 Gasification Process | 4 |
| Figure II. 1 Applications of Gasification | 11 |
| Figure II.2 Updraft Gasifier | 20 |
| Figure II.3 Downdraft Gasifier | 21 |
| Figure II.4 Crossdraft Gasifier..... | 22 |
| Figure II.5 Geldart Particle Classification | 26 |
| Figure II.6 Fluid Like Behavior of Fluidized Bed | 28 |
| Figure II.7 Pressure Drop in Fluidized Bed..... | 29 |
| Figure II.8 Bubble..... | 30 |
| Figure III.1 3D View of First Bubbling Bed Gasifier | 32 |
| Figure III.2a Screw Feeder Schematic | 40 |
| Figure III.2b Screw Feeder Section..... | 40 |
| Figure III.3 Cyclone Design Tables | 42 |
| Figure III.4 Screenshot of Excel Program-Fluidization | 43 |
| Figure III.5 Screenshot of Excel Program-Fuel | 43 |
| Figure III.6 Screenshot of Excel Program-Reactor | 44 |
| Figure III.7 Screenshot of Excel Program-Screw Feeder..... | 45 |
| Figure III.8 Screenshot of Excel Program-Cyclone | 45 |
| Figure III.9 Screenshot of Excel Program-Distributor Plate | 46 |
| Figure III.10 Bubbling Fluidized Bed Gasifier System..... | 49 |
| Figure III.12 Air Compressor | 49 |
| Figure III.13 Perlite Column | 50 |
| Figure III.14 Cooling System..... | 50 |
| Figure III.15 Kuartz Filter | 50 |
| Figure III.16 Gas Analyzer..... | 50 |
| Figure IV.1 The Bed of Cold Fluidized Bed Model | 53 |
| Figure IV.2 Pressure Drop& Air Flow Rate Graph | 54 |
| Figure IV.3 Gas properties for Typical Gas Composition HYSIS Screenshot..... | 62 |
| Figure IV.4 Gas Composition & Temperature for For Olive Cake ER 0,2 | 64 |

| | |
|--|----|
| Figure IV. 5 LHV& Temperature For Olive Cake ER 0,2 | 65 |
| Figure IV.6 Gas Composition & Temperature for For Olive Cake ER 0,3 | 66 |
| Figure IV.7 LHV& Temperature For Olive Cake ER 0,3 | 67 |
| Figure IV.8 Gas Composition & ER For Olive Cake T 850C | 68 |
| Figure IV.9 LHV& ER For Olive Cake T 850C..... | 69 |
| Figure IV.10 ER& Gas Composition For Orhaneli Coal T 850C..... | 71 |
| Figure IV.11 ER& LHV For Orhaneli Coal T 850C | 72 |
| Figure IV.12 Gas Yield& ER..... | 72 |

TABLES

| | <u>PAGE</u> |
|--|-------------|
| Table I.1 Reserves& Properties of Some Turkish Lignite | 2 |
| Table 1.2 Biomass Potential of Turkey for Energy Production | 3 |
| Table II.1 KRW coal gasification process data and equilibrium predictions | 8 |
| Table II.2 Comparison of Fixed Bed and Fluidized Bed Gasifiers..... | 24 |
| Table II.3 Sphericity of Solid Particles..... | 26 |
| Table IV.1 Ultimate Analysis of Olive Cake | 55 |
| Table IV.2 Ultimate Analysis of Olive Cake | 56 |
| Table IV.3. Calibration Results of The Screw Feeder | 60 |
| Table IV.4 Typical Biomass Gasification Gas Composition | 61 |
| Table IV.5 Experimental Matrix | 63 |
| Table IV.6 Experiment Conditions And Results of Olive Cake Set 1 | 64 |
| Table IV.7 Experiment Conditions And Results of Olive Cake Set 2 | 65 |
| Table IV.8 Experiment Conditions And Results of Olive Cake Set 3 | 67 |
| Table IV.9 Proximate Analysis of Orhaneli Coal | 70 |
| Table IV.10 Ultimate Analysis of Orhaneli Coal..... | 71 |
| Table IV.11 Experiment Conditions And Results of Orhaneli Coal..... | 71 |

I. INTRODUCTION AND AIM

The energy need of the world is increasing with the increasing population and economy. By 2030 it is estimated the world energy need will be 60% more than today. The current energy sources to supply this need are fossil energy, renewable energy and the nuclear energy. There is no other energy source. These energy sources are limited. It is estimated the oil and natural gas have 40-65 years life where coal has 230 years to be used up. The coal will continue to play important role for next decades by 2000 the 66% of the produced coal was used for electricity production where it is estimated to increase to 74% by 2030

Ministry of Energy announced that the primary energy sources production is 23.9 Mtoe while consumption is 90.2 Mtoe (millions ton of oil equivalent) by 2005. 35% of this consumption is oil, 27% is natural gas 27% is coal and the rest 11% is hydro and other renewable energy sources. General energy need of Turkey is estimated to be 126 Mtoe by 2010 and 222 Mtoe by 2020.

Turkey is dependent on imported fuels for its primary energy production. In 2004, 72% of the total energy demand of the country has been met by imported fuels It is very important for Turkey to make use of the produced biomass and coal in the country in clean energy production. If the energy recovered from biomass and coal is used in domestic heating and as process heat in industry, an additional 8-10% of the total energy will be added to the national economy.

Coal researches and utilization has been going on for many years in Turkey. But the reducing the emissions caused by the low quality coal is expensive. So the utilization of natural gas was increased while utilization is coal was decreased. The total known lignite potential of Turkey is 9.3 billion tons. 1 billion tons of it seemed to be used. General Directorate of Turkish Coal (TKI) says there is 8.3 billions ton of coal is unused by 2002. The lignite reserves of Turkey are widely spread through out the country. Where as the calorific value of the lignite is very low while ash and sulfur content is high (Figure I.1). 66.3 %of the Turkish coals have 1000-2000 Kcal/kg calorific value

only %5.2 of the has calorific value between 3000-4000Kcal/Kg. The most efficient and environment friendly way of using this coal has to be improved.

Table I.1 Reserves& Properties of Some Turkish Lignite [1]

| Location | Total Reserve (10 ⁶ tons) | Properties (%) | | | LCV (kcal/kg) |
|----------------------|--------------------------------------|----------------|-------|--------|---------------|
| | | Moist ure | Ash | Sulfur | |
| Beypazarı -Çayırhan | 186 | 21.7 | 34.4 | 4.04 | 2557 |
| Çanakkale-Çan-Durali | 85 | 23.34 | 33.2 | 3.18 | 3254 |
| Çankırı-Orta | 123 | 48.5 | 25.8 | 0.57 | 1090 |
| Sivas-Kangal | 143 | 50.0 | 21.0 | 2.02 | 1342 |
| Tekirdağ-Saray | 73 | 41.1 | 20.8 | 1.80 | 2070 |
| Kütahya-Seyitömer | 200 | 33.0 | 31.2 | 1.21 | 1900 |
| Manisa-Soma-Eynez | 308 | 13.4 | 33 | 1.29 | 3147 |
| Kütahya-Tuçbilek- | 317 | 10.6 | 48.9 | 1.46 | 2021 |
| Muğla-Yatağan | 130 | 30.0 | 24.1 | ? | 2583 |
| Elbistan | 3 357 | 50.0 | 230.0 | 1.46 | 1050 |

The total biomass energy potential of Turkey has been estimated as 50 Mtoe/yr. Out of this amount 36 Mtoe/yr is estimated to come from agro-waste. The recyclable total bioenergy amount in Turkey is about 17 Mtoe/yr. It is also very important that the use of biomass in energy production decreases the green house gas emissions causing global warming.

Biomass energy can be converted to different types of final energy (power, heat and producer gas), Wood-related industries and home owners consume the most biomass energy, lumber, pulp and paper industries burn their own wood wastes in large furnaces and boilers to supply 60% of the energy needed to run factories. In homes, wood is burned in stoves and fire places to cook meals and warm the residences. Wood is the primary heating fuel in 6.5 million homes in Turkey. Agricultural and municipal solid wastes, as energy sources are available economically in Turkey (Table I.2).

Table 1.2 Biomass Potential of Turkey for Energy Production [2]

| Biomass | Annual potential (mtons) | Energy value (mtoe) |
|-----------------------------|--------------------------|---------------------|
| Annual crops | 54,4 | 15,5 |
| Perennial crops | 16 | 4,1 |
| Forest residues | 18 | 5,4 |
| Residues from agro-industry | 10 | 3 |
| Residues from wood industry | 6 | 1,8 |
| Animal wastes | 7 | 1,5 |
| Other | 5 | 1,3 |
| Total | 116,4 | 32,6 |

The one way of using fossil fuel resources of Turkey in efficient way is Gasification process. Gasification is the thermal conversion of the carbonaceous materials to combustible gas (Figure I.2). Gasification technology offers the potential of clean and efficient energy. The technology enables the production of synthetic gas from low or negative-value carbon-based feedstock such as coal, and biomass. The gas can be used in place of natural gas to generate electricity or basic raw material to produce chemicals and liquid fuels [3]. Although it has several advantages it is still not a proven technology. There are some commercial plants and some pilot test facilities running through out the world but the researches are at very early stages in Turkey.

Fluidized Bed technology utilizes the fluidization principle in which crushed (1 –3 mm size) fuel is injected into the reactor. In the bed of the reactor The fine particles (100-600 micron) are suspended in a stream of upwardly flowing air which enters the bottom of the reactor through air distribution nozzles. The turbulent ambient inside the reactor results great mixing of hot particles and fuel, enabling high heat transfer.

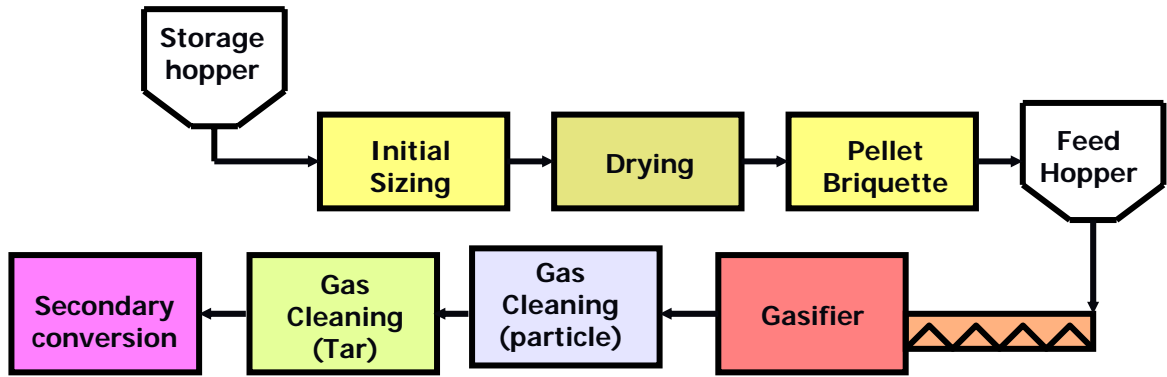

Figure I.1 Gasification Process [2]

The aim of this study is to investigate the gasification behavior of the Turkish lignite and biomass, and to optimize the process conditions and equipments to produce high calorific value tar free gas. With in this frame we developed a lab scale fluidized bed gasifier. The gasification experiments were performed with different fuel types at different process conditions like temperature and equivalence ratio. With parallel of this study also a cold model of fluidized bed was developed. Fluidization behaviors of 282micron particles

II. GENERAL BACKGROUND

Gasification is an endothermic thermal conversion technology where a carbon containing fuel is converted into a combustible gas. A limited supply of oxygen, air, steam or a combination serves as the oxidizing agent. The product gas consists of carbon monoxide, carbon dioxide, hydrogen, methane, trace amounts of higher hydrocarbons (ethene, ethane), water, nitrogen (with air as oxidant) and various contaminants, such as small char particles, ash, tars, higher hydrocarbons and oils.

Gasification technology represents a significant advancement and benefit over combustion technology due to its innate ability to control pollutants (i.e mercury from coal) and its ability to produce multiple products including: syngas, power, liquid fuels and hydrogen.

II. 1. HISTORICAL PERSPECTIVE

The earliest practical production of synthetic gas (syngas) is reported to have taken place in 1792 when Murdoch, a Scottish engineer, pyrolysed coal in an iron retort and then used the product, coal gas to light his home. [3]

Later on, Murdoch built a gas plant for James Watt, the inventor of the steam engine, and applied the technology to light one of Watt's foundries. [3]

The first gas company was established in 1812 in London to produce gas from coal and to light the west minister Bridge. In 1816 the first gas plant for the manufacture of syngas from coal was built in United State to light the streets of the city Baltimore. In 1855, the invention of the Bunsen burner premixed air and gas, allowing it to burn more economically, at very high temperatures, and without smoke. This invention added impetus to further use of gas. [3]

On December 16, 1921 a new chapter opened in the history of the energy and power industries. Fritz Winkler of Germany introduced gaseous products of combustion into the bottom of crucible containing coke particles, creating the first demonstration of gasification of coal in a fluidized bed. Winkler saw the mass of particles lifted by the

drag of the gas to look like a boiling liquid. This experiment initiated a new process called fluidization, the art of making granular solids behave like a liquid. [4]

During World War II, over 1 million air-blown gasifiers were built to produce synthetic gas from wood and charcoal to power vehicles and to generate steam and electricity. After World War II the discovery of large quantities of low-cost natural gas with heating values of about 37MJ/m^3 led to the demise of synthetic gas manufacturing industry. [3]

Interest in gasification technologies was renewed throughout the 1960s and 1970s when controversial projections suggested that natural gas reserves would be depleted and demand would exceed reserves by the 1980s and 1990s. Also the oil embargo of 1973 created awareness for the need to identify alternative sources of fuel. [3]

Throughout the 1980s, researchers and industry came to recognize some of the environmental benefits of gasification technology. More restrictive and stringent environmental standards aimed at controlling power plant emissions, and domestic and industrial waste landfills, and an increased emphasis on greenhouse gas reductions provided incentives for both government and industry stakeholders to explore and promote the commercialization of gasification technologies. [3]

Based on survey reported for 2003, there are 163 commercial gasification projects worldwide consisting of a total of 468 gasifiers. More than 120 plants began their operations between 1960 and 2000 with majority commissioned after 1980. up to 34 new plants are at various stages of planning and construction. [3]

The majority of the existing plants were designed and constructed to produce a syngas, consisting primarily of hydrogen and carbon monoxide (CO), which is used for the production of hydrogen or Fischer-Tropsches (F-T) syncrude. Hydrogen is then used to produce a wide variety of chemicals and fertilizers. The F-T syncrude is used to manufacture transportation fuels, lube oils and specialty waxes. [3]

Examples of operating plants using biomass as feed stocks include Rudersdorfer Zement project in Germany; Lahden Lampovoima Oy Project in Finland; Netherlands refinery company BV project in Netherlands; BASF plc project in United Kingdom; ASSI project and Sydkraft AB in Sweden; Portucel project in Portugal. These projects

are generally smaller (6-54 MW) than projects using coal, petcoke or heavy oil as feedstock.[3]

II. 2. LITERATURE SURVEY

Although it is possible to see commercial gasifiers, gasification is still art more than science. There are many problems of gasification still waiting to be solved. These problems differ according to fuel type, gasification process type and the conditions of the gasification process. Within this frame many attentions have been paid for many years to solve these gasification problems all over the world. Scientists have been working on the most efficient way of gasification for different kinds of fuels.

Kovacik et al. [5] studied on equilibrium calculations in coal gasification. They believed the most crucial component of gasification technology is the accurate prediction of gas quality for varying feed streams and operating conditions. They pointed that the product gas is typically composed of H_2 , CO, CH_4 , N_2 and trace amount of hydrocarbons, and its composition is a function of gasification reactor operating temperature and pressure as well as the fed coal and feed gas composition. According to study prediction of gas composition is almost impossible using available kinetic data about coal gasification, because it is required large number of knowledge about dynamic data. So they used another approach to estimate product gas which is chemical equilibrium. Realistically coal gasification system should reach the chemical equilibrium if the operating temperature and pressure of the system is high i.e the gasification reaction rates are high. Kovacik et al. says the problems in applying this technique are (i) at what operating temperature and pressure can one assume that the gasification process is at chemical equilibrium, (ii) what percentage of the feed coal is gasified in the reactor, (iii) what operating temperature should be used for equilibrium calculations. They assumed for practical purpose that the reactor temperature should be below ash melting temperature. They calculated the equilibrium chemical composition by minimizing the Gibbs free energy for given temperature and pressure. They performed equilibrium calculations at commercial software called FACT. They compared the calculated gas composition with the experimental data available for Texaco, PRENFLO and KRW gasification processes. Product gas composition derived from the equilibrium

calculations were compared with those obtained experimentally. The best fit temperature which predicted product gas composition using chemical equilibrium was obtained by minimizing the combined least square errors between calculated and the measured values. The calculated values were very close to measured ones. At Table II.1 it can be easily seen that the best fit temperatures both agree well with the corresponding measured averaged bed temperature.

Table II.1 KRW coal gasification process data and equilibrium predictions[5]

| Highvale coal Analysis (wt %) | | | | Setpoint 1 | Setpoint 2 | | Setpoint 1 | Setpoint 2 |
|-------------------------------|-------|-------|-------------------------------------|------------|------------|---------------------------------------|------------|------------|
| C | 50,42 | 50,42 | Average Bed Temperature (K) | 1174 | 1194 | Best Fit Temperature (K) | 1210,2 | 1230 |
| H | 3,34 | 3,34 | Product Gas Composition (Dry, mol%) | | | Predicted Gas Composition (Dry, mol%) | | |
| N | 1,22 | 1,22 | CO | 9,5 | 10,8 | CO | 9,25 | 10,66 |
| O | 11,18 | 11,18 | H ₂ | 13,1 | 12,7 | H ₂ | 13,9 | 13,59 |
| S | 0,17 | 0,17 | CO ₂ | 13,5 | 12,9 | CO ₂ | 12,4 | 11,9 |
| Ash | 11,91 | 11,91 | CH ₄ | 1,3 | 1,1 | CH ₄ | 0,004 | 0,004 |
| Moisture | 21,76 | 21,76 | N ₂ | 62,5 | 62,5 | N ₂ | 64,37 | 63,81 |
| | | | H ₂ S+CO | 0,05 | 0,06 | H ₂ S+CO | 0,033 | 0,31 |

From the work, Kovacic et al. demonstrated that gasifier product compositions can be calculated using chemical equilibrium software for wide range of gasifiers. For gasifiers temperatures above 1300K the calculated product gas composition assuming chemical equilibrium was found to be intensive to reactor temperature.

Murakami et al [6] worked on dual fluidized bed consist of one bubbling fluidized bed gasifier and one circulating fluidized bed combustor. They also simulated the process on Aspen simulation program and tried to optimize the process. Chen et al worked on biomass gasification on circulating fluidized bed and tried to isolate the devolatilization and gasification processes from combustion process. Based on this concept they developed a model including fluid dynamics, kinetic chemical reactions and mass and energy balance.

Cao et al.[7] believed that A tar-free fuel gas can be obtained in a properly designed biomass gasification process. In their study, a tar-free biomass gasification process by air was proposed. Their concept was demonstrated on a lab-scale fluidized

bed using sawdust under autothermic conditions. This lab-scale model gasifier combined two individual regions of pyrolysis, gasification, and combustion of biomass in one reactor, in which the primary air stream and the biomass feedstock were introduced into the gasifier from the bottom and the top of the gasifier respectively to prevent the biomass pyrolysis product from burning out. The biomass was initially pyrolysed and the produced char was partially gasified in the upper reduction region of the reactor, and further, char residue was combusted at the bottom region of the reactor in an oxidization atmosphere. An assisting fuel gas and second air were injected into the upper region of the reactor to maintain elevated temperature. The tar in the flue gas entered the upper region of the reactor and was decomposed under the elevated temperature and certain residence time. This study indicated that under the optimum operating conditions, a fuel gas could be produced with a production rate of about $3.0 \text{ Nm}^3/\text{kg}$ biomass and heating value of about 5000 kJ/Nm^3 . The concentration of hydrogen, carbon monoxide and methane in the fuel gas produced were 9.27%, 9.25% and 4.21%, respectively. The tar formation could be efficiently controlled below 10 mg/Nm^3 . The system carbon conversion and cold gasification efficiency reached above 87.1% and 56.9%, respectively. In addition, the investigation of energy balance for the scale-up of the proposed biomass gasification process showed that the heat loss could be recovered by approximately 23% of total energy input. Thus, partial fuel gas that was produced could be re-circulated and used to meet need of energy input to maintain the elevated temperature at the upper region of reactor for tar decomposition. It was predicted the heating value of product fuel gas would be 8000 kJ/Nm^3 if the system was scaled up.

Ibanez et al. [21] tested olive cake in a 300 kWth atmospheric circulating fluidized-bed (CFB) gasification facility using air as a fluidization agent. In this paper, the effect of experimental conditions on gasification process with the aim of enhancing the gas production and improving its composition and energetic content was analyzed. The first tests have demonstrated that the CFB test rig operates adequately and makes it possible to carry out gasification experiments with olive cake as a fuel. The gasifier is 0,2m in diameter and 6,5 m in height. Solid recirculation is carried out using a cyclone, a standpipe and a J-valve. The lower heating value of the producer gas obtained is $3:8 \text{ MJ=Nm}^3$ at the lowest temperature (780°C). The carbon conversion in olive cake

gasification at the 800°C set points was in the range of 81.0–86.9%. The increase in equivalence ratio did not improve carbon conversion significantly. The gas yield increases when equivalence ratio increases. After leaving the gasifier, the producer gas enters into a post-combustion chamber where propane gas can be injected to support combustion. The main stream of gas leaving the post-combustion chamber is then cooled into a water scrubber (0.47 m internal diameter) and the particles carried by the flue gas are removed as well. The olive cake gasification tests were operated in the ER range of 0.4–0.7 to study its effect on the gas quality, with respect to heating value and raw gas yield, and on the gasification process. The results show that the equivalence ratio significantly affects the gas composition. Generally, increasing the equivalence ratio decreased the concentration of the combustible components (CO, H₂, CH₄, C₂H₄, and C₂H₆) and increased the CO₂ concentration. Also the maximum amount of H₂ (9.3 vol. %) is obtained at an ER of 0.59 and an upper zone temperature which is the highest one (893 C). When ER ranges from 0.59 to 0.73, it has little effect on the hydrocarbons. From these experimental tests, the gas yield varies from 2.9 Nm³/kgfuel-daf at an ER of 0.41 to 5.6 Nm³/kgfuel-daf at an ER of 0.73. Hence, it goes without saying that when ER increases, the gas yield significantly increases, but the heating value of the gas decreases. At the ER range studied of 0.4–0.7, the carbon conversion varied between 81.0% and 86.9%. That is to say that an increase in equivalence ratio yields only a slight increase in carbon conversion. A carbon conversion of 86.9% is reached in the CFB gasification of olive cake at a 0.73 equivalence ratio and one of 81.0% at a 0.41 equivalence ratio.

II. 3. APPLICATIONS

One of the uses of the gasification process is Integrated Gasification Combined Cycle (IGCC). In Integrated Gasification Combined-Cycle (IGCC) systems, the syngas is cleaned of its hydrogen sulfide, ammonia and particulate matter and is burned as fuel in a combustion turbine (much like natural gas is burned in a turbine). The combustion turbine drives an electric generator. Hot air from the combustion turbine can be channeled back to the gasifier or the air separation unit, while exhaust heat from the

combustion turbine is recovered and used to boil water, creating steam for a steam turbine-generator

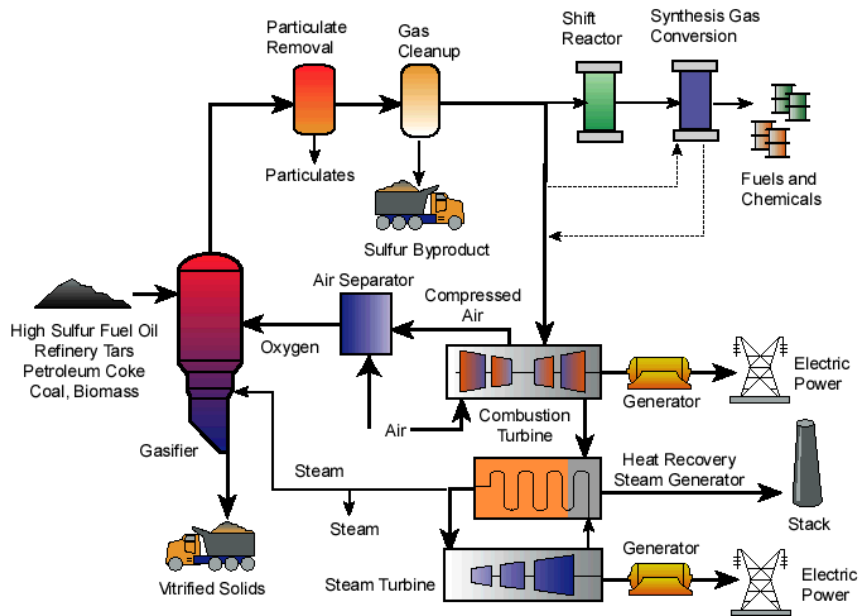

Figure II. 1 Applications of Gasification [8]

Another application of gasification gas is production of electricity from fuel cell. The CO and H₂ in the syngas is fed in to fuel cell which would increase electrical efficiency.

The syngas can also be processed using commercially available technologies to produce a wide range of products, fuels, chemicals, fertilizer or industrial gases. Some facilities have the capability to produce both power and products from the syngas, depending on the plant's configuration as well as site specific technical and market conditions.

II. 4. THE CHEMISTRY OF GASIFICATION

In the gasification following chemical processes take place.

1. Drying >150°C
2. Pyrolysis 150-700°C
3. Combustion 700-1500°C

4. Reduction 800-1100°C

Processes 1,2 and 4 consumes the heat provided by exothermic combustion processes.

II. 4. 1. Drying

Basically in the drying process, the moisture in the solid fuel evaporates.

II. 4. 2. Pyrolysis

The pyrolysis process separates the water vapor, organic liquids and noncondensable gasses from the char or solid carbon fuel. A series of complex physical and chemical processes occur during the Pyrolysis processes, which start slowly at less than 350°C, accelerating to an almost instantaneous rate above 700°C. The composition of the evolved products is a function of the temperature, pressure and the gas compositions during the pyrolysis. The pyrolysis process is initiated at around 230°C when the thermally unstable components such as lignin in biomass and volatiles in coal are broken down and evaporate with other volatile components

The vaporized liquid product contains tar and polyaromatic hydrocarbons (PAH). The tar being sticky represents a great challenge to downstream machines like filters engines. If the pyrolysis could be made to pass through a high temperature (1100 to 1200°C) zone a large fraction of the tar would break down to smaller hydrocarbons. The heating value of the gas produced in pyrolysis is low (3,5-9MJ/Nm³)

The pyrolysis generally produces the following three products.

1. Light gases such as H₂, CO, CO₂, H₂O, CH₄
2. Tar, a black, viscous and corrosive liquid composed of heavy organic and inorganic molecules
3. Char, a solid residue mainly containing carbon

II. 4. 3. Combustion

The oxidation or combustion of char is one of the most important chemical reactions taking place inside the gasifier, providing practically all the thermal energy

needed for the endothermic reactions, Oxygen supplied to the gasifier reacts with the combustible substances present, resulting in the formation of CO₂ and H₂O which subsequently undergo reduction upon contact with the char produced from pyrolysis

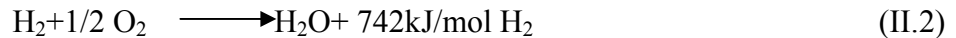
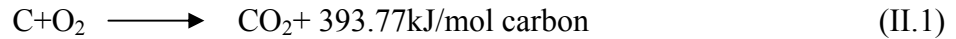

II. 4. 4. Reduction

Reduction –also called gasification- involves a series of endothermic reactions supported by the heat produced from the combustion reactions. Gasification yields combustible gases such as hydrogen, carbon monoxide and methane through a series of reactions.

1. Water-gas reaction
2. Boudouard reaction
3. Shift conversion
4. Methanation

II. 4. 4. 1. Water-Gas Reaction

Water-gas reaction is the partial oxidation of the carbon by steam, which could come from a host of different sources, such as water vapor associated with incoming air, vapor produced from the evaporation of water, and pyrolysis of the solid fuel. Steam reacts with the hot carbon according to the heterogeneous water-gas reactions:



II. 4. 4. 2. Boudouard Reaction

The carbon dioxide present in the gasifier reacts with char to produce CO according to the following endothermic reaction. This reaction is much smaller than combustion reactions at the same temperature.

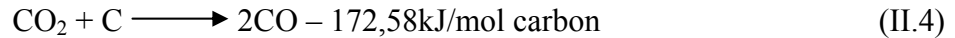

II. 4. 4. 3. Shift Conversion

The heating value of hydrogen is higher than that of carbon monoxide. Therefore, the reduction of steam by carbon monoxide to produce hydrogen is a highly desirable reaction.

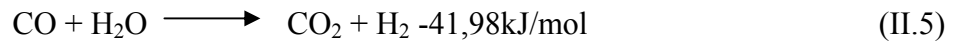

II. 4. 4. 4. Methanation

Methane could also form in the gasifier through the following overall reaction.

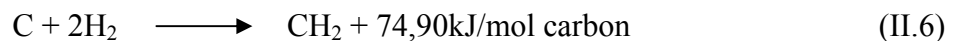

II. 5. ADVANTAGES OF GASIFICATION

The environmental benefits stem from the capability to cleanse as much as 99 percent of the pollutant-forming impurities from coal-derived gases. Sulfur in coal, for example, emerges as hydrogen sulfide and can be captured by processes used today in the chemical industry. In some methods, the sulfur can be extracted in a form that can be sold commercially. Likewise, nitrogen typically exits as ammonia and can be scrubbed from the coal gas by processes that produce fertilizers or other ammonia-based chemicals.

Coal gasification may offer a further environmental advantage in addressing concerns over the atmospheric buildup of greenhouse gases, such as carbon dioxide.. If oxygen is used in a coal gasifier instead of air, carbon dioxide is emitted as a concentrated gas stream. In this form, it can be captured more easily and at lower costs for ultimate disposition in various sequestration approaches. (By contrast, when coal burns or is reacted in air, 80 percent of which is nitrogen, the resulting carbon dioxide is much more diluted and more costly to separate from the much larger mass of gases flowing from the combustor or gasifier.)

Efficiency gains are another benefit of coal gasification. In a typical coal combustion plant, heat from burning coal is used to boil water, making steam that drives a steam turbine-generator. Only a third of the energy value of coal is actually converted into electricity by most combustion plants, the rest is lost as waste heat.

A coal gasification power plant, however, typically gets dual duty from the gases it produces. First, the coal gases, cleaned of their impurities, are fired in a gas turbine - much like natural gas - to generate one source of electricity. The hot exhaust of the gas turbine is then used to generate steam for a more conventional steam turbine-generator. This dual source of electric power, called a "combined cycle," converts much more of coal's inherent energy value into useable electricity. The fuel efficiency of a coal gasification power plant can be boosted to 50 percent or more.

Future concepts that incorporate a fuel cell or fuel cell-gas turbine hybrid could achieve even higher efficiencies, perhaps in the 60 percent range, or nearly twice today's typical coal combustion plants. And if any of the remaining waste heat can be channeled into process steam or heat, perhaps for nearby factories or district heating plants, the overall fuel use efficiency of future gasification plants could reach 70 to 80 percent. [28]

II. 6. OPERATING PARAMETERS OF GASIFICATION

There are many important parameters that affect the product gas chemical composition and heating value.

- Fuel characteristics
 - Fuel reactivity
 - Moisture content

- Ash content
- Volatile matter
- Temperature
- Particle Size
- Operating Pressure
- Gasification agent
 - Air
 - Oxygen
 - Steam
- ER

II. 6. 1. Fuel Characteristics

II. 6. 1. 1. Fuel reactivity:

In general reactivity of coal decreases with its rise in rank. Physical properties of fuel such as particle size and porosity have significant effects on the kinetics of coal gasification. As the particle size becomes smaller, specific contact area between the coal and reaction gases increases, resulting in faster reactions. [9]. For low and medium rank coals the reactivity in gasification increases with an increase in pore volume and surface area, but high rank coal (C>85%), the reactivity is not affected by changes in pores. In high rank coals, the pore size are so small that the reaction diffusion controlled. [4]

II. 6. 1. 2. Moisture content

Moisture content is found by keeping the fuel sample at 378K in an inert atmosphere at ambient pressure until no change in mass is observed. It changes between 5-40%. High moisture content of fuel lowers the temperature inside the gasifier since evaporation is endothermic. So there is an optimum limit for good gasification which is about %35 for fixed bed gasification and 5-10% for fluidized bed applications. [4]

II. 6. 1. 3. Ash content

Ash content does not affect the gas product directly. Actually it affects the gasifier operation conditions. Each fuel has characteristic ash melting point temperature. Gasifier should operate below this temperature. This prevents the agglomeration of the ash.

II. 6. 1. 4. Volatile matter

Volatile matter content of a fuel is determined by keeping of the sample at 1300K in an inert atmosphere until no change in mass is observed. Fuels with higher volatile matter content are more reactive and therefore can be converted more easily in to gas producing less char.

II. 6. 2. Temperature

The temperature is the second most important operation parameter for the gasification process. [10]. The system should operate in the temperature range of 1100-1300K to produce hydrogen rich gas. [11]

II. 6. 3. Particle Size

The particle size of the feedstock material depends on the hearth dimensions but is typically 10–20% of the hearth diameter. Larger particles can form bridges which prevent the feed moving down, while smaller particles tend to clog the available air voidage, leading to a high pressure drop and the subsequent shutdown of the gasifier. [12].

II. 6. 4. Operating Pressure

The gasifiers can be either atmospheric pressure or pressurized. Atmospheric pressure operations are more common and relatively proven technology. The most important problem of the Pressurized gasifiers is the feeding systems. Pressure has also effect on gas composition. Considering gasification reactions we can easily say that CO and H₂ formation decreases with increasing pressure while CH₄ formation increases. Because of this the pressurized gasifiers are commonly used in IGCC technology.

II. 6. 5. Gasification agent

Gasification agent can be air, oxygen, steam or mixture of these. Air gasification produces low heating value gas containing about %50 N₂, while oxygen and steam gasification produce medium heating value gas with very little or no N₂. The oxygen gasification requires air separation unit for producing oxygen which is too expensive. Steam gasification needs an extra heating source since it is endothermic.

II. 6. 6. Equivalence Ratio

In a combustor the amount of air supplied is basically defined by the stoichiometry, which depends on the fuel composition, and excess air requirement. In a gasifier the air supply is only a fraction of the stoichiometric rate. Equivalence ratio (ER) defined as the ratio of actual air fuel ratio to stoichiometric air fuel ratio [4] The quality of gas obtained from a gasifier strongly depends on the value of ER. The gasification efficiency was maximized with an optimum range of air ratio of 0,25-0,33 [11]

II. 7. TYPES OF GASIFIERS

Three of the mainly used reactor types for gasification are entrained bed fixed bed and fluidized bed. Entrained bed gasifiers are mainly used for pulverized fuels with oxygen in co-current flow. Fixed bed reactors can have updraft, downdraft or very seldom cross-draft depending on mass flow direction. The systems of choice for fluidized bed gasification are bubbling and circulating beds. They differ in respect of fluidizing velocity and gas path.

II. 7. 1. Entrained Bed Gasifier

In the entrained flow gasifier a dry pulverized solid, an atomized liquid fuel or a fuel slurry is gasified with oxygen (much less frequent: air) in co-current flow. The gasification reactions take place in a dense cloud of very fine particles. Most coals are suitable for this type of gasifier because of the high operating temperatures and because the coal particles are well separated from one another. The high temperatures and pressures also mean that a higher throughput can be achieved; however thermal

efficiency is somewhat lower as the gas must be cooled before it can be cleaned with existing technology. The high temperatures also mean that tar and methane are not present in the product gas; however the oxygen requirement is higher than for the other types of gasifiers.

II. 7. 2. Fixed Bed Gasifier

In fixed bed gasifiers the gasification medium flows through the fixed bed of fuel particles. This type of gasifier can be divided into three depending upon flow direction of gasification medium through fuel.

II. 7. 2. 1. Updraft Gasifier

The air intake is at the bottom and the gas leaves at the top. Near the grate at the bottom the combustion reactions occur, which are followed by reduction reactions somewhat higher up in the gasifier. In the upper part of the gasifier, heating and pyrolysis of the feedstock occur as a result of heat transfer by forced convection and radiation from the lower zones. The tars and volatiles produced during this process will be carried in the gas stream. Ashes are removed from the bottom of the gasifier.

The major advantages of this type of gasifier are its simplicity, high charcoal burn-out and internal heat exchange leading to low gas exit temperatures and high equipment efficiency, as well as the possibility of operation with many types of feedstock (sawdust, cereal hulls, etc.).

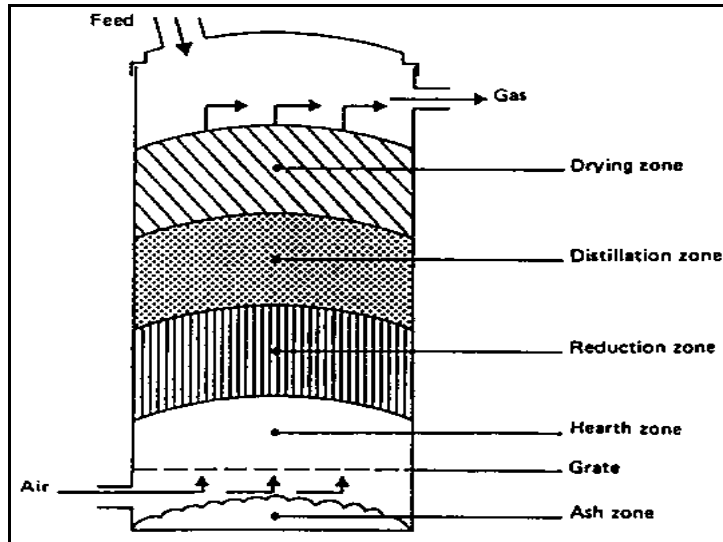

Figure II.2 Updraft Gasifier

Major drawbacks result from the possibility of "channeling" in the equipment, which can lead to oxygen break-through and dangerous, explosive situations and the necessity to install automatic moving grates, as well as from the problems associated with disposal of the tar-containing condensates that result from the gas cleaning operations. The latter is of minor importance if the gas is used for direct heat applications, in which case the tars are simply burnt

II. 7. 2. 2. Downdraft Gasifier

A solution to the problem of tar entrainment in the gas stream has been found by designing co-current or downdraught gasifiers, in which primary gasification air is introduced at or above the oxidation zone in the gasifier. The producer gas is removed at the bottom of the apparatus, so that fuel and gas move in the same direction, as schematically shown in Fig On their way down the acid and tarry distillation products from the fuel must pass through a glowing bed of charcoal and therefore are converted into permanent gases hydrogen, carbon dioxide, carbon monoxide and methane.

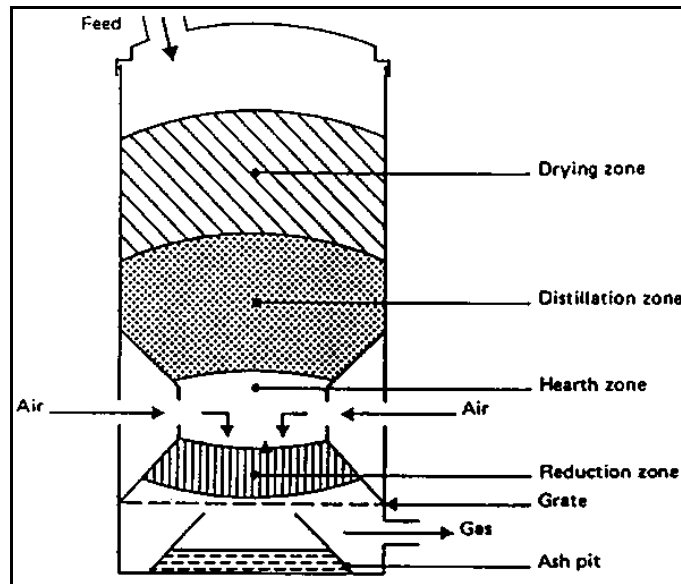

Figure II.3 Downdraft Gasifier

Depending on the temperature of the hot zone and the residence time of the tarry vapors, a more or less complete breakdown of the tars is achieved. The main advantage of downdraft gasifiers lies in the possibility of producing a tar-free gas suitable for engine applications.

II. 7. 2. 3.Cross-Draft Gasifier

Schematically illustrated in Figure II.4 is an adaptation for the use of charcoal. Charcoal gasification results in very high temperatures (1500°C and higher) in the oxidation zone which can lead to material problems. In cross draught gasifiers insulation against these high temperatures is provided by the fuel (charcoal) itself.

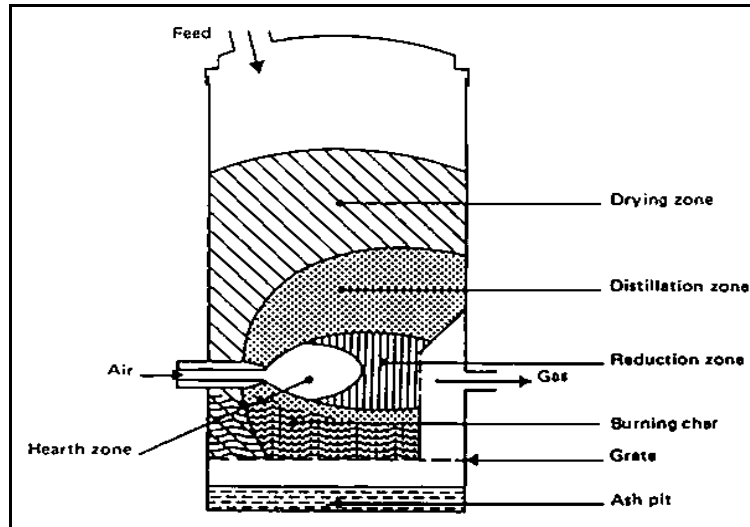

Figure II.4 Crossdraft Gasifier

Advantages of the system lie in the very small scale at which it can be operated. Installations below 10 kW (shaft power) can under certain conditions be economically feasible. The reason is the very simple gas-cleaning train (only a cyclone and a hot filter) which can be employed when using this type of gasifier in conjunction with small engines.

A disadvantage of cross-draught gasifiers is their minimal tar-converting capabilities and the consequent need for high quality (low volatile content) charcoal

II. 7. 3. Fluidized Bed Gasifier

When a gas flow is introduced through the bottom of a bed of solid particles, it will move upwards through the bed via the empty spaces between the particles. At low gas velocities, aerodynamic drag on each particle is also low, and thus the bed remains in a fixed state. Increasing the velocity, the aerodynamic drag forces will begin to counteract the gravitational forces, causing the bed to expand in volume as the particles move away from each other. Further increasing the velocity, it will reach a critical value at which the upward drag forces will exactly equal the downward gravitational forces, causing the particles to become suspended within the fluid. At this critical value, the bed is said to be fluidized and will exhibit fluidic behavior. By further increasing gas velocity, the bulk density of the bed will continue to decrease, and its fluidization

becomes more violent, until the particles no longer form a bed and are “conveyed” upwards by the gas flow.

In fluidized bed gasifiers air and fuel are mixed in a hot bed of bed material. Due to the intense gas-solid mixing in a fluidized bed, different zones –drying, pyrolysis, oxidation, reduction- cannot be distinguished. Contrary the fixed bed gasifiers, the air to fuel ratio can be changed, and as a result the bed temperature can be controlled easily. The product gas however, always contains some tar, which needs to be removed.

Fluidized bed gasifiers have several advantages over the other type of gasifiers which are

1. Higher throughput than fixed bed gasifier
2. Improved heat and mass transfer from fuel
3. High heating fuel
4. Reduced char

Fluidized bed gasifiers can be operated on different types.

II. 7. 3. 1. Bubbling Fluidized bed Gasifier

Bubbling fluidized bed (BFB) gasifiers consist of a vessel with a grate at the bottom through which air is introduced. Above the grate is the moving bed of fine-grained material into which the prepared biomass feed is introduced. Regulation of the bed temperature to 700–900°C is maintained by controlling the air/biomass ratio. The biomass is pyrolysed in the hot bed to form a char with gaseous compounds, the high molecular weight compounds being cracked by contact with the hot bed material, giving a product gas with a low tar content, typically <1–3 g/Nm³. This types of gasifiers are usually used for up to 25MW capacities.

II. 7. 3. 2. Circulating Fluidized Bed Gasifiers (CFB)

In this type of gasifiers the air velocity is high enough to remove particles outside the reactor. The hot particles are collected by a cyclone separator and turn back to the bed. This is much better in terms of heat and mass transfer, residence time and carbon conversion. This type of application is used for up to 100MW systems.

II. 7. 4. Comparison of Fixed Bed and Fluidized Bed Gasifiers

Each type of reactor has its advantages and limitations. In the case of reactor technology, fixed beds have a wide temperature distribution. This includes possibilities for hot spots with ash fusion, low specific capacity, long periods for heat-up and a limited scale-up potential. For plants with high power requirement the limited scale-up includes higher investment costs for a cascade of single fixed beds. To avoid channeling the feedstock has to be as uniform as possible. The brief comparison of fixed bed and fluidized bed gasifiers are given in Table II.2.

Table II.2 Comparison of Fixed Bed and Fluidized Bed Gasifiers

| Countercurrent fixed bed with gas recycle | Atmospheric bubbling bed |
|--|---|
| (-) Higher investment (about 10%), two lines | (+) Lower investment |
| (-) Feedstock fines must be agglomerated | (+) No problems with feedstock fines |
| (-) Particle size as uniform as possible | (+) Broad particle size distribution |
| (+) Very great particle size possible (up to 100 mm) | (-) Limited particle size (up to 50 mm) |
| (+) Nearly tar free gas | (-) High tar content in the gas (1 g/m ³) |
| (+) High carbon conversion rate (90±99%) | (-) Low carbon conversion rate (90%) |
| (+) Discharge of liquid slag | (-) Ash fusion by low-softening ash |

The main advantages are the high carbon conversion efficiency, the wide range of ash content in the feedstock and the possibility to melt the ash. Furthermore, co-current fixed beds produce a clean gas with very low tar content. Fluidized beds have good heat and material transfer between the gas and solid phases with the best temperature distribution, high specific capacity and fast heat-up. They tolerate wide variations in fuel quality and a broad particle- size distribution. Disadvantages of fluidized beds are high dust content in the gas phase and the conflict between high reaction temperatures with good conversion efficiency and low melting points of ash components, e.g. alkali. For plants with low capacity fixed beds (or grates) have no investment disadvantage. For a plant with a capacity of 15 MWth if two fixed beds were chosen, investment is 10% higher than with a single fluidized bed. The additional costs for preparing feedstock to a uniform particle size can be 10% of the plant costs. On the other hand, the additional

precipitator for tar at the fluidized bed system is in the same cost range. The pretreatment and storage of feedstock in general, without agglomeration, requires approx. 25% of the plant costs. The costs for the reactor, excluding the boiler, are only about 10% of the total costs. [24]

II. 8. CHARACTERISTICS OF SOLID PARTICLES

A particle may be defined as a small object having a precise physical boundary in all directions. The particle is characterized by its volume and interfacial surface in contact with the environment [4].

II. 8. 1. Particle Size Measurement

There are many ways to measure particle size. For big particles direct measurement with micrometers are used. For tiny particles in direct methods like microscope is used. Between these extreme particles the sieving method is used. There are many standards for sieving. Particles greater than 44microns are measured using a set of standard sieves. The test sieves are put one above another, and vibrated for 20-30 minutes. The particles collected on each sieve are weighed and assigned a size by taking arithmetical average of the aperture of the sieve.

$$D_m = 1 / \sum (x_i / d_i) \quad (II.7)$$

Where d_i is the arithmetic mean of the opening of two adjacent sieves, and x_i is the weight fraction of samples collected between two sieves.

II. 8. 2. Sphericity

Sphericity is a measurement of the deviation of the particle from the sphere shape
Sphericity $\emptyset = (\text{surface area of sphere} / \text{surface area of particle})$
 $\emptyset = 1$ for sphere and $0 < \emptyset < 1$ for all other particles. Below table calculated sphericity of some particles are listed in Table II.3.

Table II.3 Sphericity of Solid Particles

| Material | Sphericity |
|----------------|------------|
| Sand average | 0.75 |
| Limestone | 0.45 |
| Coal (crushed) | 0.40 |

II. 8. 3. Voidage

Because of the particle shapes a volume between particles occurs. This is called voidage and defined by

$\epsilon = \text{void volume} / \text{volume of (particle + voids)}$ according to Brown et al the fraction voids ϵ in a packed bed is related to the sphericity of particles.[13]

II. 8. 4. Particle Classification

Geldart classified the solids under four groups. A, B, C, and D

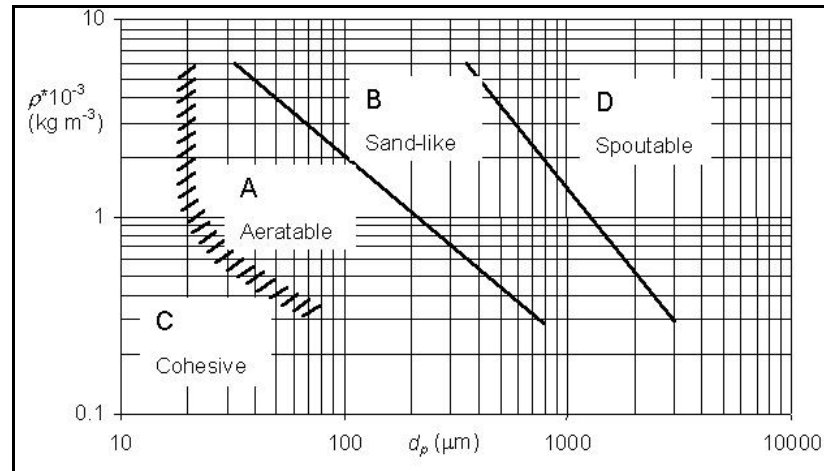

Figure II.5 Geldart Particle Classification

This classification is plotted against density difference between the solids and the fluidizing gas.

II. 8. 4. 1. Group C

These particles are very fine and generally smaller than 30 microns. The interparticle forces are comparable to the gravitational forces on these particles. These particles are difficult to fluidize. If you try to fluidized it results in channeling.

II. 8. 4. 2. Group A

These particles are typically in the range of 30-100microns. These particles fluidize well but expand considerably after exceeding the min fluidization velocity and before bubbles starts appearing. Generally Circulating fluidized bed systems uses group A particles

II. 8. 4. 3. Group B

These particles are typically in the range of 100-500microns. These particles fluidize well and bubbles appear as soon as the minimum fluidization velocity. Majority of fluidized bed systems use these group particles.

II. 8. 4. 3. Group D

They are the biggest of all particles typically >500micron. They require much higher velocity to fluidize. Some bubbling beds uses this group particles.

II. 9. FLUIDIZATION PHENOMENA

A fluid passes upward through a bed of fine particles cause particles to move. When flow rate reaches a certain amount, drag force of fluid becomes equal to gravitational force. This causes particles to stay in suspended position. The pressure drop through any section of the bed about equals the weight of fluid and particles in that section. The bed is considered to be just fluidized and it is called minimum fluidization. At this point the bed display fluid-like behaviors which are;

- A denser object than the bed density will sink where lighter will float
- The bed surface maintains its horizontal level independent of the bed's position

- When a hole is drilled any where on the vessel the particles will be rained just liquid
- If two vessels with different bed levels connected each other the level of the beds will be equal
- The static pressure at any level through the bed is approximately equal to the weight of the solid beds.

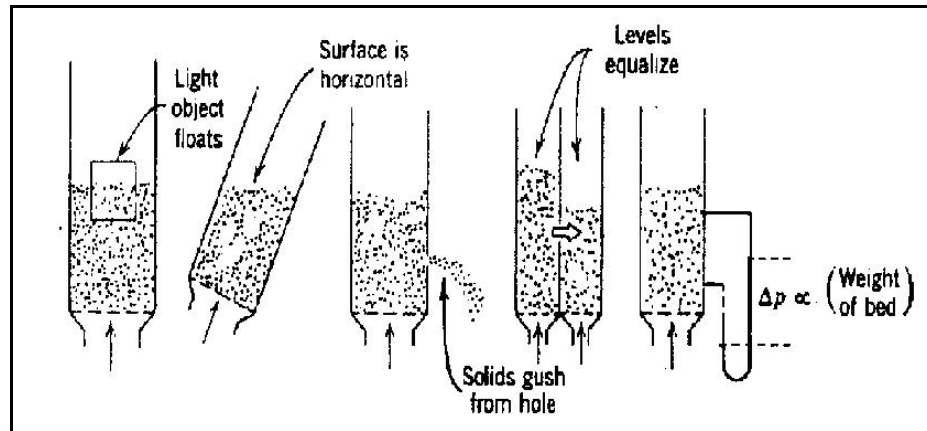

Figure II.6 Fluid Like Behavior of Fluidized Bed

If the gas velocity is increased still further, expansion of the bed will continue to occur; the solid particles will become somewhat separated from each other and begin to jostle each other and move around in a restless manner. Increasing the velocity just a slight amount causes further instabilities and some of the gas starts bypassing the rest of the bed in the form of bubbles. These bubbles grow in size as they rise up the column. Coincidentally with this, the solids in the bed begin moving upward, downward, and around in a highly agitated fashion, appearing as a boiling frothing mixture. With part of the gas bubbling through the bed and the solids being moved around as though they were part of the fluid, the bed of particles is said to be *fluidized*. It is in a state of aggregative, nonparticulate, or bubbling fluidization. A further increase in gas velocity will result in slug flow and unstable chaotic operation of the bed. Finally, at extremely high velocities the particles are blown or transported out of the bed [14]

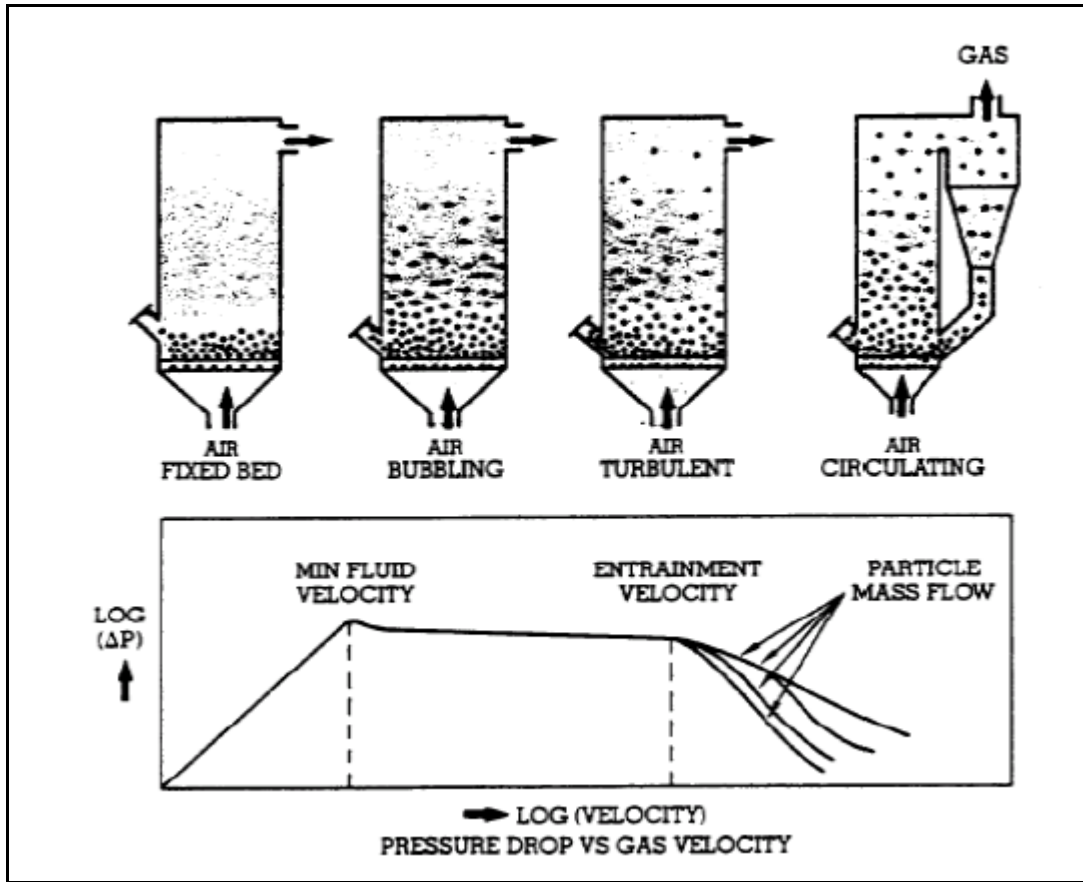

Figure II.7 Pressure Drop in Fluidized Bed [25]

II. 9. 1. Packed Bed

The fluid passes through the bed of particles but doesn't cause particles to move. Drag forces of the particles causes pressure drop across the bed.. The pressure drop across the bed is equals the weight of the bed and formulated by Ergun [15] as

$$\Delta P_A = AL(1-\epsilon)(\rho_p - \rho_g)g \quad (II.8)$$

II. 9. 2. Bubbling Fluidized Bed

If the gas flow rate through the fixed bed is increased, the pressure drop due to the fluid drag continues to rise as per Ergun equation until the superficial gas velocity reaches a critical value known as the minimum fluidization velocity, U_{mf} . At the

velocity where fluid drag is equal to a particle's weight less its buoyancy, the fixed bed transforms into a incipiently fluidized bed. The minimum fluidization velocity at which the bed just becomes fluidized (U_{mf}) may be obtained by Ergun equation

$$\frac{\Delta P}{L} = 150 \frac{(1-\epsilon)^2}{\epsilon^3} \frac{\mu U}{(\phi d_p)^2} + 1,75 \frac{(1-\epsilon)}{\epsilon^3} \frac{\rho_g U^2}{\phi d_p} \quad (II.9)$$

Where;

$\frac{\Delta P}{L}$ = Pressure drop for unit height of the bed

ϵ = void fraction

μ = viscosity of the fluid

ϕ = Sphericity of the particle

d_p = The average particle diameter

ρ_g = Density of the fluid

U = min fluidization velocity

At minimum fluidization, the bed behaves as pseudoliquid. For group B and D particles a further increase in gas flow can cause the excess gas to flow in the form of bubbles. The gas solid suspension around the bubbles and elsewhere in the bed is called emulsion phase (Figure II.8).

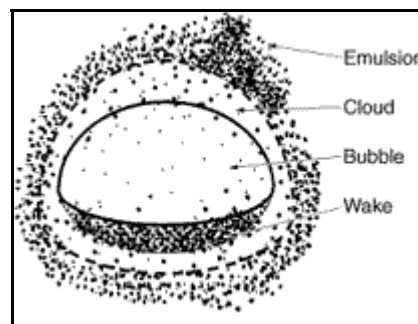

Figure II.8 Bubble

A fluidized bed of Group A particles does not start bubbling as soon as the superficial velocity exceeds the U_{mf} , but instead the bed starts expanding. The bubbles start appearing when the superficial gas velocity exceeds another characteristic value called minimum bubbling velocity U_{mb} [4]. U_{mb} for group A particles is given by Abrahamsen and Geldart (1980) as [16];

$$U_{mb} = 2.07 \exp(0.716F) d_p \left[\frac{\rho_g^{0.06}}{\mu^{0.347}} \right] \quad (II.10)$$

Where F is the mass fraction of particles less than 45micron

At sufficiently high fluid flow rate the terminal velocity of solids is exceeded the upper surface of the bed disappears entrainment becomes appreciable, and solids are carried out of the bed with the fluid stream. In this state we have fluidized bed with pneumatic transport of solids

III. METHODOLOGY

Two different bubbling gasifiers and one cold fluidized bed have been built within the scope of this thesis. First gasifier helped us to see what is missing and what the hints are to design a good lab scale gasifier. We faced different problems and tried to find solutions for them. Finally we designed our second bubbling gasifier which worked very well. In the scope of this thesis the design of second bubbling fluidized bed gasifier is explained in detail while one can find brief explanation about the first gasifier.

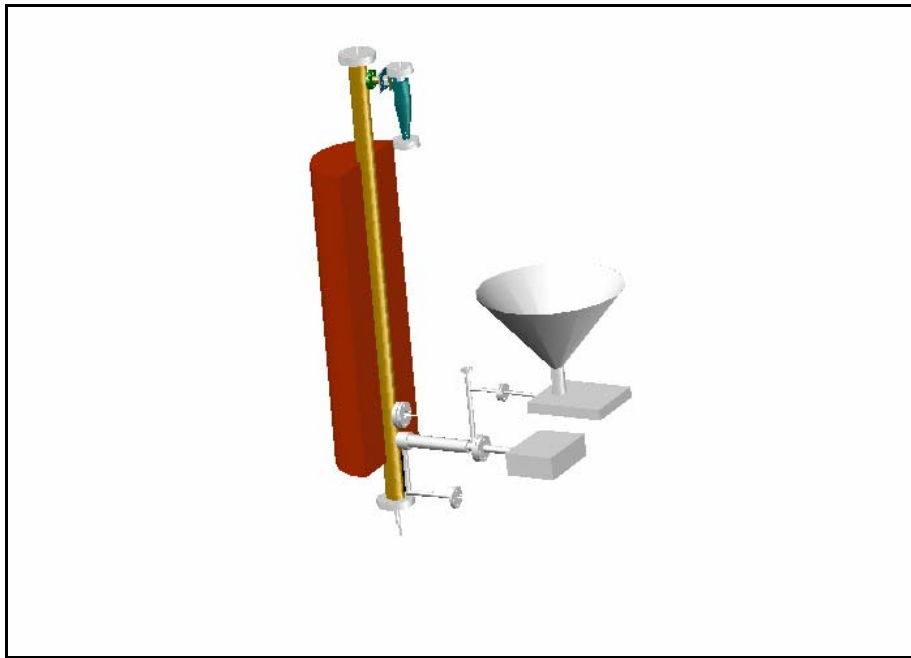

Figure III.1 3D View of First Bubbling Bed Gasifier

First BFB gasifier was 2 kg/hr in capacity and 1.3m in height. It was being heated by an electrical furnace. Electrical heater was split type. We were placing the gasifier inside the heater. The feeding system of the gasifier weren't letting us to close the furnace. Although we tried to close the open area with insulation material, big amount of heat loss occurred during the experiment. Screw feeder of the first system was fixed to the reactor. When a blockage occurred it was very difficult to clean the feeding system. Another problem was about ash extraction. The diameter of the ash extraction pipe was

too small (20mm) so that it was very difficult to extract the ash. Generally we were dismantling all the system to clean it. The gas cleaning principle was exactly the same with the latest one, including cooling system, perlite column and quartz filter.

Having great experience with the first BFB gasifier we designed the second BFB gasifier. The detail design of the second BFB gasifier will be explained at the following chapters. The design includes reactor, distributor plate, screw feeder and cyclone design.

In different stages of the design some necessary assumptions were made. The design starts by defining the system capacity and selecting an average fuel composition. Then we found the fluidization velocity and the operation velocity. These data helped us to find the reactor area. Selecting a suitable residence time from literature helped us to define the reactor height.

After reactor dimensioning the distributor plate was designed. Again some assumptions such as orifice velocity and distributor plate pressure were made.

The third step of the design was feeding system design. A suitable screw feeder according to max fuel feeding capacity and selected fuel type will be designed.

The final step was the cyclone separator design. A proper cyclone dimensioning by making some assumptions and using some design tables will were done.

A simple excel program was written to make all design calculations. The program composed of 6 sheets for design of fluidized bed gasifier and 3 sheets for evaluating experiment results. Design sheets consists of fluidization calculation sheet, fuel properties and air calculation sheet, reactor dimensioning sheet, screw feeder design sheet, cyclone design sheet and distributor plate design sheet. Evaluation of results sheet composed of result, calculation and design table sheets.

Design of the cold model was not based on complex calculations. A standard 80mm diameter plexi glass pipe was selected with height of 1.5m. Plexi glass is transparent material and easy for machining. By using cold model min fluidization velocity was found experimentally and results were compared with the theoretical calculations.

III. 1 GASIFIER DESIGN

Design of the reactor composed of serial of calculations including gasification air need and fluidization velocity. Reactor is the most important part of gasification system. Reactor should be design in a way that gasification reactions must reach chemical equilibrium, solid particles must fluidize well and necessary residence time should be reached for defined fuel type. Necessary steps to design a gasification reactor are listed below

- a) Select a fuel type
- b) Find stiochiometric air need for combustion for selected fuel
- c) Select ER and find air need for gasification and air flow rate inside the reactor
- d) Select bed material type and particle diameter
- e) Find min fluidization velocity and operation velocity for selected bed material
- f) Divide air flow rate to the min fluidization velocity to find the reactor area

III. 1. 1. Selection and Analyses of Fuels

Selection of fuel type and fuel feeding capacity is the first step of design. After selection of fuel type necessary analysis should be done such as proximate analysis, ultimate analysis and heating value determination which help us to define fuel characteristics. Defining fuel characteristics will help us to define the necessary air for desired ER. This is very important because one of the major problems of gasification is not to be able to keep steady state conditions. This is most probably caused by unstable feeding or poor fuel characteristics determination.

III. 1. 1. 1. Proximate analysis

Proximate analyze is performed by Thermo gravimetric Analyze equipment according to ASTM D 5142-04 standard. Proximate analysis gives us the moisture content, volatile matter, ash content and fixed carbon values.

III. 1. 1. 2. Ultimate Analysis

Ultimate analyze is performed by Elemental analysis equipment. Ultimate analysis gives us the major components of fuel the as wt% carbon, hydrogen, nitrogen, sulfur, and oxygen. From these values stoichiometric air need calculations are done.

III. 1. 1. 3. Heating value [16]

The heating value or calorific value of a substance, is the amount of heat released during the combustion of a specified amount of it. The calorific value is a characteristic for each substance. It is measured in units of energy per unit of the substance, usually mass, such as: kcal/kg, kJ/kg, J/mol, Btu/m³. Heating value is commonly determined by use of a bomb calorimeter.

The heat of combustion for fuels is expressed as the HHV or LHV,

- The quantity known as higher heating value (HHV) (or *gross calorific value* or *gross energy* or *upper heating value*) is determined by bringing all the products of combustion back to the original pre-combustion temperature, and in particular condensing any vapor produced. This is the same as the thermodynamic heat of combustion since the enthalpy change for the reaction assumes a common temperature of the compounds before and after combustion, in which case the water produced by combustion is liquid.
- The quantity known as lower heating value (LHV) (or *net calorific value*) is determined by subtracting the heat of vaporization of the water vapor from the higher heating value. This treats any H₂O formed as a vapor. The energy required to vaporize the water therefore is not realized as heat

III. 1. 2. Stoichiometric Air Need For Combustion

To find the necessary air to gasify a fuel we should first find the stoichiometric air need for ER=1.

The reactions are the following



The stiochiometric air need is found by the formula

$$8,89C+26,7(H-\frac{O}{8})+3,34S \quad [17] \quad (III.5)$$

Where C, H, O and S represent the mass flow rates of Carbon, Hydrogen, Oxygen and the Sulfur respectively.

III. 1. 3. Selection of ER for Gasification

ER is an important assumption for design. Although ER is a operating parameter and will be tried in different ranges during experiments we have to assume an ER for the beginning. From the literature one can say most convenient ER for biomass gasification changes between 0.25-0,35 [11]. Also reactor temperature should be defined to define the air properties at determined temperature. The operation temperature of atmospheric fluidized beds is generally around 800°C-900°C.

The air need at the full capacity for the gasification is found by multiplying ER with stiochiometric air found in Eq III.5

After defining the air need as mass basis we should find the volumetric air flow rate. This is found by;

$$Q_{air} = \frac{\dot{m}_{air}}{\rho_{air@800C}} \quad (III.6)$$

III. 1. 4. Fluidization velocity

Min fluidization velocity is the fourth step of the design. After finding min fluidization velocity we will assume an operation velocity which must be smaller than the terminal velocity of the smallest particle. The min fluidization velocity is found by Ergun equation (Eq. II.9) which is explained in detail at section II.10.2.

We should also define the bed material to put unknowns in the formula to find U_{mf} . For bubbling fluidized beds generally Group B particles are used (Section II. 9. 4. 3). The bed material is generally selected as Silica sand which consist of 90% silica and 10% others. Silica sand can be easily found from cement industry. The below characteristic properties of the silica sand should be known to apply Ergun equation

- Density
- Average Particle diameter
- Sphericity
- Void fraction

III. 1. 5. Reactor Cross Sectional Area and The Height

After defining the air flow rate for gasification and operation velocity which enables bed materials to fluidized, one can easily calculate the reactor cross sectional area by dividing the air flow rate to the operation velocity U_o .

$$A = \frac{Q}{U_o} \quad (III.7)$$

III. 2. DISTRIBUTOR PLATE DESIGN

The distributor plate supports the bed materials and homogeneously distributes the fluidizing gas into the bed of the solids. This is an important aspect of the design of the fluidized bed because beyond the distributor plate there is no other physical means for influencing the distribution of the gas through the solids. [4]

The primary function of a distributor plate is to distribute the fluidizing air uniformly across the cross section of the bed. This uniformity should be maintained under all operating conditions. [4]

BFB gasifiers use a relatively coarse particle and low fluidizing velocity. If the fluidizing gas above the distributor is not uniformly distributed, the air velocity in one region could drop the min fluidizing velocity of the bed materials. The air will thus fail to fluidize the coarser particles making the section partially defluidized. Fuel particles burning at fluidized section will fail to dissipate their heat and lead to local hot spots. As a result, the temperature of the particles in this region will rise above their softening temperature allowing the particles to stick to each other. [4]

The most practical design of bubbling beds keep the distributor pressure drop within 15%- 30% of the bed drop

$$\frac{\Delta P_d}{\Delta P_b} = 0,15-0,3$$

The gas Velocity through an orifice U_o is related to the pressure drop through the grid as

$$U_o = C_D \left[\frac{2\Delta P_d}{\rho_{gor}} \right]^{0.5} \quad (III.8)$$

Where ΔP_d distributor plate pressure drop and ρ_{gor} is the density of the gas (kg/m³) passing through the orifice. Orifice coefficient C_D , is given by Zenz as 0,8. [26]

If N is the number of orifices diameter (d_o) per unit area of the distributor, the orifice velocity U_o and the superficial gas velocity U , may be related to the fraction of the grid plate opened for gas by using the mass balance as follows:

$$N \frac{\pi}{4} d_o^2 U_o \rho_{gor} = U \rho_g \quad (III.9a)$$

$$N \frac{\pi d_o^2}{4} = \frac{U \rho_g}{U_o \rho_{gor}} \quad (\text{III.9b})$$

Here, N depends on the arrangement of orifice on the plate and the pitch P:

$$N = \frac{2}{\sqrt{3}P^2} \text{ for triangular pitch}$$

$$N = \frac{1}{P^2} \text{ for square pitch}$$

III. 3. SCREW FEEDER DESIGN

The feeder system for lab scale fluidized bed systems are generally screw feeder type system. Screw feeders are devices suitable for handling a wide variety of materials that have good flowability characteristics. The screw feeder has a helicoidally surface fitted on a shaft that rotates inside a fixed tube. The material which comes out of the silo is pushed by the helicoids flight along the base of the tube in the direction of transport. The advantages of the screw feeder include the possibility of having different openings, each with its own shut-off organ for unloading the material [18]

Design Steps for the screw feeder are listed below

- a) Select pitch diameter
- b) Select Pitch
- c) Select shaft Diameter
- d) Select RPM
- e) Use formula to find fuel feeding rate

The feeder is thought to be two stage screw feeder, which includes two screws. The first screw is the one which controls the feeding rate by controlling motor

frequency. The fuel is dropping to the second screw which turns at high speed to spread fuel out through the reactor.

The screw calculations are done according to max feeding capacity.

Below parameters should be known for the screw feeder design

- Pitch diameter (D_p)
- Pitch (P)
- Shaft diameter (D_s)
- RPM (N)
- Density of fuel (d)
- Axial velocity (V_a)
- Tangential velocity (V_t)

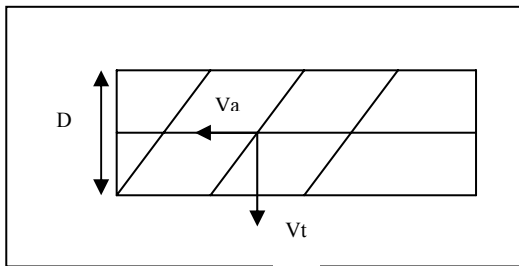

Figure III.2a Screw Feeder Schematic

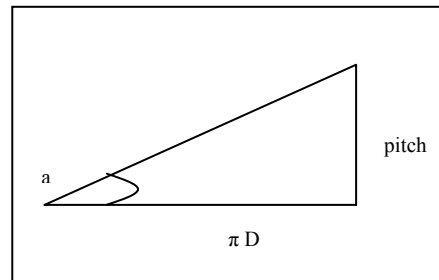

Figure III.2b Screw Feeder Section

Below assumptions should be made to design a screw feeder:

| | | |
|---------------------------|---|---|
| Pitch diameter (D_p): | } | Restricted by manufacturing capabilities. |
| Pitch (P): | | |
| Shaft diameter (D_s): | | |
| RPM (N): | | Restricted by motor and reactor. |
| F: | | Depends on fuel type |

One should assume the above parameters. Most of them are restricted by manufacturing capabilities. For industrial applications screw manufacturing is not big problem, desired dimensions may be satisfied for different manufacturing techniques, but for small scale systems this is not possible and the designer must stay at the standard dimensions.

After assuming the parameters and changing them in the limits of capabilities, the fuel feeding rate is tried to be satisfied by using below formula.

$$\text{Feeding capacity} = d \times A \times V_a \times f \times 3600 \quad (\text{III.10})$$

III. 4. CYCLONE DESIGN

Gas solid separator is one of indispensable part of the fluidized bed systems. Electrostatic separators and bag house filters are used for cold gas cleaning and usually for particle emission controls. At the hot gas cleaning side, the cyclone separators are used. Cyclones are easy to manufacture, highly resistant to high temperature and have high collection efficiencies. In the cyclone gas enters a cylindrical or conical chamber tangentially at one or more points and leaves through a central opening. The dust particles, by virtue of their inertia, will tend to move toward the outside separator wall, from which they are led into a receiver. A cyclone is essentially a settling chamber in which gravitational acceleration is replaced by centrifugal acceleration. At operating conditions commonly employed, the centrifugal separating force or acceleration may range from 5 times gravity in very large diameter, low-resistance cyclones, to 2500 times gravity in very small, high-resistance units. The immediate entrance to a cyclone is usually rectangular. [19]

Design Steps of a Cyclone is explained below

- a) A proper inlet velocity is assumed. The Cyclone inlet velocities are usually chosen between 20 to 30 m/s.
- b) Find the gas flow rate at inlet of the cyclone

Gas flow rate is found by mass balance. Mass inlet is air and solid. Mass outlet is gas and ash.

$$\text{Total Mass in} = \text{Total mass out} ; \quad \dot{m}_{\text{air}} + \dot{m}_{\text{fuel}} = \dot{m}_{\text{gas}} + \dot{m}_{\text{ash}} \quad (\text{III.11})$$

This gives the mass flow rate. We should know the density of the gas at the cyclone inlet conditions to find the gas flow rate. To do this one should assume a gas composition. After that density can easily be found

$$Q_{\text{gas}} = \frac{\dot{m}_{\text{gas}}}{\rho_{\text{gas}}} \quad (\text{III.12})$$

c) Find inlet area of cyclone by dividing flow rate by inlet velocity

$$H \times W = \frac{\text{Gas flow rate}}{\text{inlet velocity}} \quad (\text{III.13})$$

d) Choose the Cyclone type from the Figure III.3 to define the coefficients.

e) By using inlet area find the diameter of the cyclone and the other dimensions.

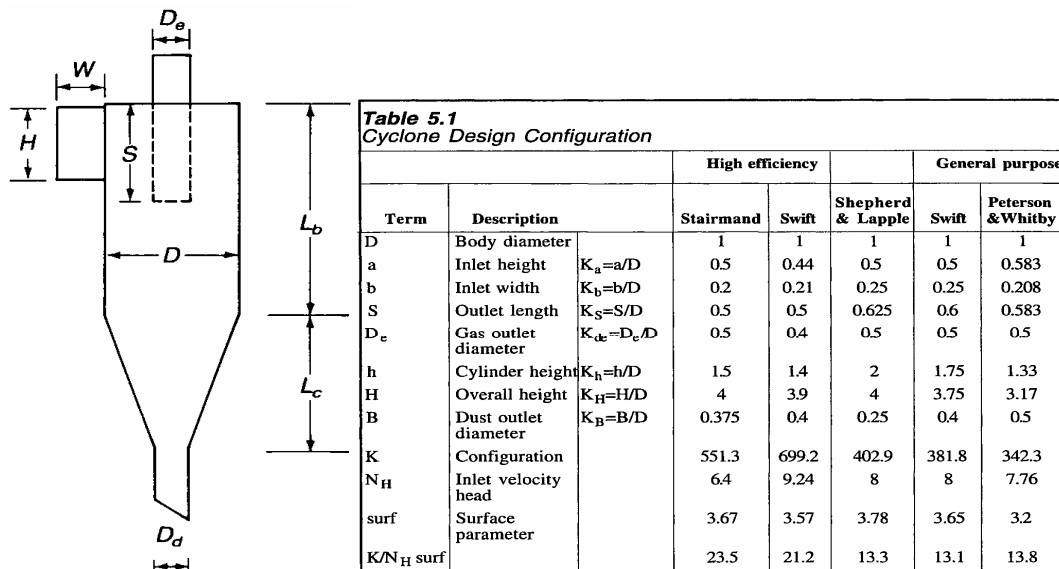

Figure III.3 Cyclone Design Tables

III. 5. EXCEL PROGRAM

The calculations that are used in the Excel program are based on the equations described above. The fluidization sheet (Figure III.4) calculates the minimum fluidization velocity by using Ergun Equation (Eq II.9) for given particle and fluidization agent at 27°C and 825°C. The blue cells in figures are the inputs. These inputs are depends on the fluidization gas and particle properties.

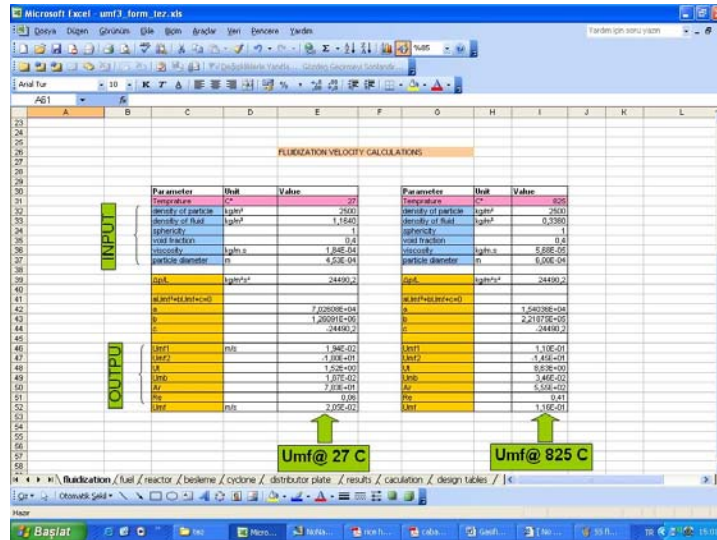

Figure III.4 Screenshot of Excel Program-Fluidization

Fuel sheet (Figure III.5) calculates the air need for the defined typed of fuel for different ERs. The blue cells on the left are the inputs. At this side the fuel elemental analyses data must be given by the designer. Also the fuel feeding capacity must be given too. At the right side of the sheet the necessary air is calculated according to Eq.III.5 for different ERs (0,25- 0,30-0,35-1,2). The results are given as L/min m³/h, g/min and kg/h at 25 °C and 800 °C for each.

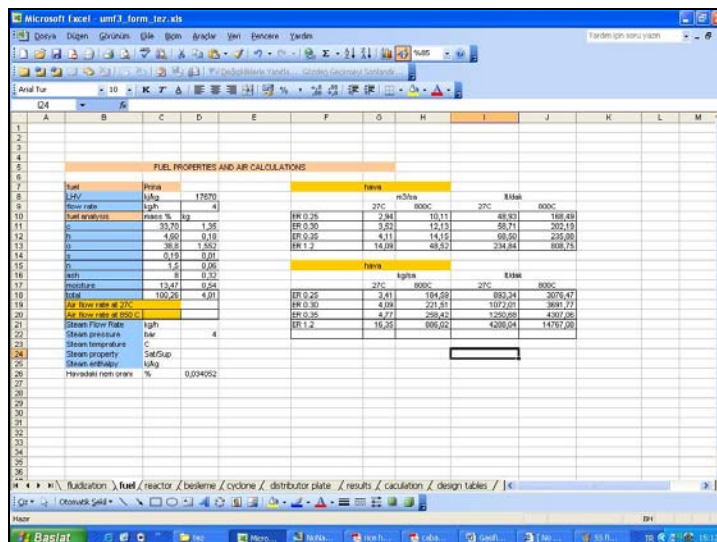

Figure III.5 Screenshot of Excel Program-Fuel

Reactor sheet (Figure III.6) calculates the reactor dimensions as diameter and height by using the data coming from the fluidization sheet and the fuel sheets. The inputs at this sheet are Residence time which has primary effect determining the reactor height and the flow rate inside the reactor which is coming from the mass balance Eq. II.17.

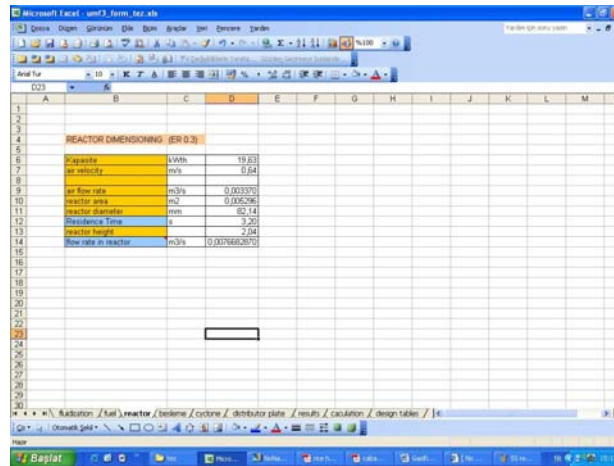

Figure III.6 Screenshot of Excel Program-Reactor

Screw feeder sheet (Figure III.7) design the screw feeder. In this part, the design is made by trial an error method. The variables listed on Section III. 3 are tried in different combinations to reach the desired fuel feeding capacity. The values of the variables are generally depends on the manufacturing capability.

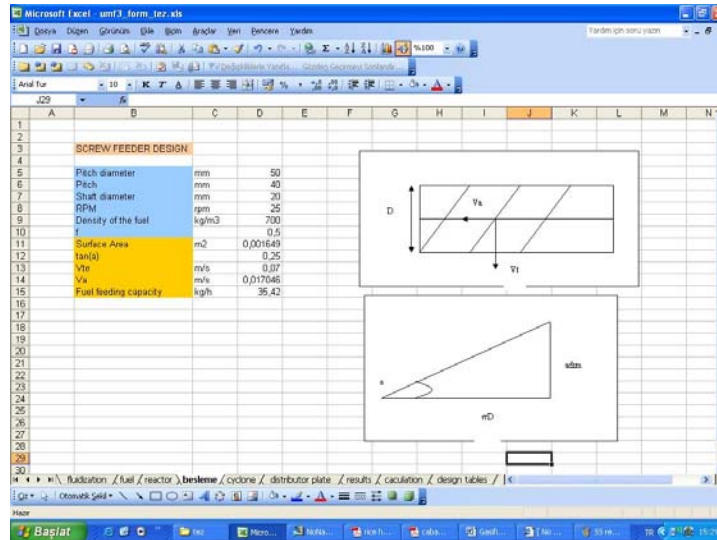

Figure III.7 Screenshot of Excel Program-Screw Feeder

Cyclone sheet (Figure III.8) determines the cyclone dimensions. In this section the only input is the cyclone inlet velocity. The flow rate of the gas is came from the mass balance Eq III.11 an Eq. III.12, then by using III.13 cyclone inlet area is found. From this data all the dimensions can be defined by using the Shapperd&Lapple cyclone data from the Figure III.3. The dimensions found here may not be integer or standard. Especially for the body of the cyclone the standard pipe must be used so the calculated values can be floored to the nearest standard pipe dimensions.

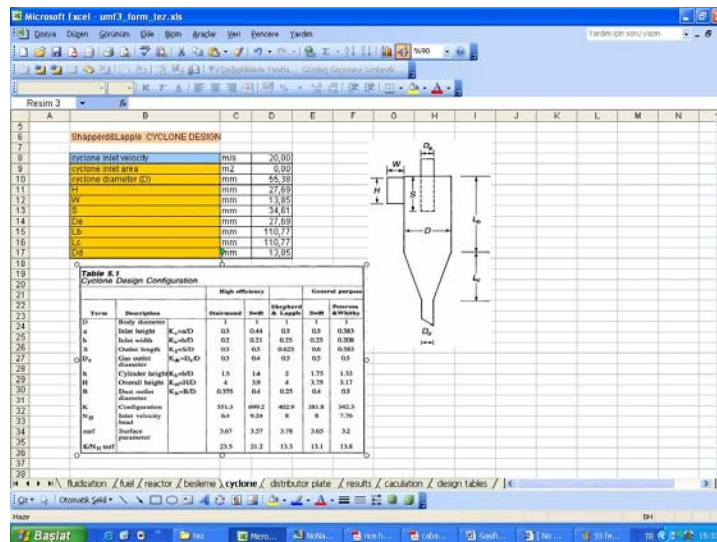

Figure III.8 Screenshot of Excel Program-Cyclone

Distributor plate sheet (Figure III.9) calculates the necessary number of holes for given orifice diameter by using Eq III.8 and Eq. III.9 The inputs are the orifice diameter which generally is taken as 1-1,5mm and drag coefficient which is usually taken as 0,8.

The screenshot shows an Excel spreadsheet titled 'umf3_form_tez.xls'. The table contains the following data:

| DISTRIBUTOR PLATE DESIGN | | | |
|--------------------------|-------------------|--|--------|
| orifice diameter | m | | 0,0015 |
| Cd | | | 0,80 |
| Qp | pa | | 482,78 |
| q | kg/m ³ | | 1,16 |
| bed height | m | | 0,07 |
| U ₀ | m/s | | 23,08 |
| N | number/cm | | 0,45 |
| pitch | mm | | 14,00 |
| disk sayisi | | | 25 |
| islandipine sayisi | | | 7,6 |

Figure III.9 Screenshot of Excel Program-Distributor Plate

III. 6. MANUFACTURING OF THE SYSTEM

Manufacturing process of the system mainly included welding and machining. All of the equipments were machined at the workshop of TUBITAK-MAM. Since the operating temperature of the system is 800°C. Design temperature was selected as 1000°C due to possible sudden temperature increases.

The material of the reactor was selected as high temperature refractory steel ASTM A 312 AISI 310S pipe which can withstand against 1100°C at low pressures. The operating pressure of the system was atmospheric so we did not care about the wall thickness. Wall thickness was selected as sch 10S (2,77m for 3” pipe) which was easy to find from the market. The flanges of the reactor were selected as DN 80 PN 10.

6mm holes were drilled through the reactor at 11 points for measurement devices .There is one pressure measurement point below and one above distributor plate. Other pressure points are at above the bed, middle of the reactor and exit of the reactor. Temperature points are in the bed at the middle of and exit of the reactor. 6mm AISI

316L tubes were welded to the measurement points. These tubes are 20 cm long to stay out of the insulation. Thermocouples are placed inside the 6mm pipes in a way that the ends of the thermocouples are in the middle of the reactor. Thermocouples are connected to the tubes with fittings. Pressure points are exactly the same as temperature points.

Feeding system was connected to the gasifier with flange. This enables us to clean the feeding system which is highly expected to be blocked. There is water jacket at the last 25 cm of the screw to prevent pyrolysis in the screw. There is also N₂ purge point against backflow of the gas.

Distributor plate is nozzle type distributor plate. Nozzles were made of 10mm tubes. Their ends were blinded. At each nozzle 4 holes were drilled with 45 degree inclined to prevent backflow of the particles. Nozzles were placed on a flange. There is a 30mm hole in the middle of the flange for ash extraction. Distributor plate was placed between two flanges. A wind box with 30cm height was placed under distributor plate.

There are two air inlets one is primary air inlet and placed at the bottom of the gasifier. The other one is secondary air inlet and placed at the middle of the reactor. Primary and secondary air inlets are both connected with ¼" fitting. Secondary air inlet was not used with in scope of this thesis. There is also one steam inlet at the bottom of the reactor for further studies. Steam gasification is also not in the scope of this thesis.

III. 7. COLD FLUIDIZED BED MODEL AND ANCILLARIES

Cold model is 70mm in diameter and 2m in height. Riser of the model composed of two parts each having 1m height and connected with flange. The distributor plates are placed to the bottom of the model and placed between two flanges. Four pressure measurement points are placed on the model which one of them is just below the distributor plate while the others are just above the distributor plate, above the bed, in the middle of the riser and at the exit of the riser. The differential pressures were measured by Almemo differential pressure connector and data were logged by Almemo data logger. Air flow rate was measured by Alborg mass flow controller.

III. 8. GASIFICATION SYSTEM AND ITS ANCILLARIES

The BFB gasification system shown in Figure III.10 consists of gasifier, screw feeder, cyclone and gas cleaning system. The system is heated electrically which enables to control temperature easily. There are two KANTHAL electrical heaters through the reactor each having 65 cm height. Each heater has its own pid controller. The thermocouples of the controller are directly connected to the reactor, so that we know the temperature that we see from the heater panel is the temperature inside the reactor. Main gas stream continues to chimney while a small stream is taken for gas analyzing soon after the cyclone exit. The reactor is 2,15 m in height with 80mm diameter. Max thermal capacity of the system is 20kWth. Technical Drawings of the system at Appendix A.



Figure III. 10 Bubbling Fluidized Bed Gasifier System

Feeder system is two stage screw feeder. There are two screws and two Lerroy Somer electric motors for both stage. The motors have 0,37 kW power. First stage screw motor has variable speed controller to control fuel feeding rate. The second stage motor has also variable speed controller but generally operates at fixed speed (300-500 RPM).

Air is fed from a Atlas Copco (Figure III.12) compressor which has max flow rate of 70 l/min. There is a moisture trap after compressor to be sure moisture free air is fed. There is Alborg mass flow controller (Figure III.11) to control air flow rate which has 0-100 l/min measuring range .



Figure III.11 Mass Flow Controller



Figure III.12 Air Compressor

A small stream is taken soon after the cyclone exit. The stream is introduced to a gas cleaning system to prevent the analyzer down. Gas cleaning system consists of cooler, perlite column (Figure III.13) and quartz filter (Figure III.15). Cooler system has collector to collect condensed tar. The cooler is cooled by Cole Parmer water cooling system (Figure III.14). This system also cools the water for the screw feeder cooling. Perlite column is made of glass so that we can easily see if the gas is clean enough or not. There is a pump sucking gas from the gas cleaning system. Pump delivers the gas stream to the online gas analyzer. ABB online gas analyzer (Figure III.16) is used for gas analyzing. ABB analyzer is measuring CO, CO₂, CH₄, H₂ and O₂. The system has its own gas cooling and filters. The gas cooled up to 5 °C also there is a moisture sensor which cuts the line if feels the moisture. We can easily conclude that all the measurements are in dry basis.



Figure III.13 Perlite Column



Figure III.14 Cooling System



Figure III.15 Kuartz Filter



Figure III.16 Gas Analyzer

Ash is collected by a pipe. Pipe opening is in the middle of the distributor plate. Exit of the pipe is at the bottom of the gasifier. There is a valve at the exit. After the experiment the ash is collected by opening this valve.

III. 9. EXPERIMENTAL WORK

In the scope of this thesis one biomass and one coal fuel were tested. These are Olive cake, and Orhaneli coal. The main aim was to find the best operating conditions to get high heating value gas. Tests were performed at different operating conditions. Mainly temperature and equivalence ratio were changed to reach the optimum conditions.

For olive cake three set of tests were performed. Each set have 4 experiments. At the first two set, the effect of temperature was observed by fixing ER at 0,2 and 0,3. and changing temperature between 750°C and 900°C. At the third set of test, the ER effect was observed. Temperature was kept constant at 850°C and ER was changed between 0,2 and 0,35

For Orhaneli coal one set of tests were performed having 4 experiments. During the experiment the temperature was kept constant and the effect of ER was observed changing it between 0,25 and 0,40

Following variables were measured during experiments

- All the gases (O₂, CO, CO₂, CH₄, H₂) online
- All the flow rates (fuel, air, nitrogen)
- Temperatures throughout the reactor

III. 9. 1. Start-up

15 cm fixed bed height is kept for all experiments. The bed material is fed before each experiment from the feeder system. The system is fed air during bed material feeding, to prevent blockage inside the reactor. Then the water cooling system is set to 2 °C and started. It takes almost one hour to reach water 2 °C from 19 °C. The electrical heater is set to operating temperature and starts. At the same time Electrical heaters are set to operating temperature and started. Air feeding is continued during heating to preserve heaters.

III. 9. 2. Experiment

When system reaches the desired temperature, feeding is started. Then the sucking pump is started to suck the gas to the gas analyzer. Analyzer responds the changes immediately. Systems is observed continuously, when it reaches the steady state data is collected. Data collection is performed every two minutes. All the gases, air feeding rate, nitrogen feeding rate (if any) and the reactor temperature are noted. Steady state measurement is performed for 10-20 minutes.

III. 9. 3. Shut down

After data collection, air and fuel feeding are cut, pump is stopped and heaters and cooler are shut down. For safety reasons, all the electrical connections are stopped and air circulation fans are run in the laboratory. The system is waited to be cool down.

III. 9. 4. Post Experiment

When we sure the system is cooled to the room temperature, We start to clean the system. The bed material and the ash are collected from the ash collection system. Ash collection system has a valve at the bottom of the system. The materials are collected from here. Fly ash is collected from the cyclone. Collected ashes and the bed material are weighted after experiment. Some times agglomeration is observed inside the reactor. At this time the top of the system is opened and the agglomerated stones are broken with a steal stud.

IV. RESULTS AND DISCUSSIONS

IV.1. COLD MODEL EXPERIMENTAL RESULTS

First test were done with 282 micron silica sand The fluidization agent was selected as air the properties of the sand and air at 27°C are given below

- Density of sand 2500kg/m³
- Void fraction 0,4
- Sphericity of sand 1
- Viscosity of air 1,84E-5N.s/m²
- Density of air 1,16 kg/m³

When we put the unknowns in Ergun equation Eq. II.9 We find the min fluidization velocity as 0,0775 m/s.



Figure IV.1 The Bed of Cold Fluidized Bed Model

After finding min fluidization velocity with Ergun equation we put 282 micron sand into the cold model and run it. The test result is given below

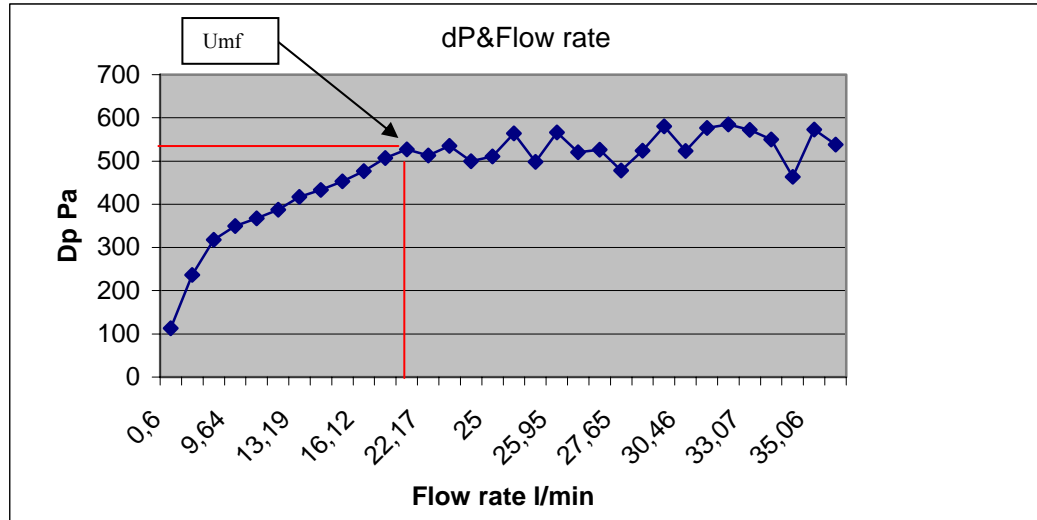

Figure IV.2 Pressure Drop& Air Flow Rate Graph

This graph represents the pressure drop change with respect to air flow rate. Table resulted from the experiment is very similar to literature (Figure II.7). The min fluidization occurs at the first peak. In this case the min fluidization occurs at 20,45 L/min air flow rate.

Dividing air flow rate by reactor cross sectional area we can find the min fluidization velocity

$$U_{mf} = \frac{20,45 \text{ l/min}}{((70\text{mm})^{-3})^2 \pi / 4} \frac{1 \text{ m}^3}{1000} \frac{1 \text{ min}}{60 \text{ sec}} = 0,0886 \text{ m/s}$$

The result is very close to theoretical calculation which was 0,0775 m/s. This result is quite acceptable. The deviation of experimental result from the calculation is 12.5% probably due to air leaks through the reactor, and measurement errors.

IV.2 GASIFIER DESIGN CALCULATIONS

The design calculations of the system were made by following the steps that described in detail in Section III. The results of the calculations were sometimes floored to the integer numbers or standard dimensions.

IV. 2. 1. Selection and Analyses of fuel

Turkey is one of the 6 Mediterranean countries that meet %90 oil need of the world. Turkey has 7% share of total oil production with its 169×10^3 tons/year production capacity. [20] Only a 21% of the weight of an olive is the oil itself, the remaining 79% consists of water, plus skin, and pit. In the oil mills where the olives are pressed, most of their oil content is extracted. The solid waste that results from this extraction process is called olive oil cake (Pirina in Turkish), and it is the raw material used by olive cake oil extractors to obtain the residual oil. [21] Olive oil cake is one of the most important biomass sources for energy production.

The analyses of the olive cake were performed by TUBITAK-EE solid fuel analyses laboratory. Proximate analyze were performed with LECO TGA701 Thermo gravimetric Analyze equipment according to ASTM D 5142-04 standard. Ultimate analyze were performed with LECO Truspec CHN-S Elemental analyze equipment., Carbon (C), Hydrogen (H) and Nitrogen (N) were defined according to ASTM D 5373-02 standard while Sulfur (S) is according to ASTM D 4239-05 .Samples were dried at 105 °C for 2 hours before analyses. Proximate analyses, Elementary analyses and heating value determination results are given table IV.1 and IV.2.

Table IV.1 Ultimate Analysis of Olive Cake

| Ultimate Analysis of Olive Cake | |
|---------------------------------|--------------------------|
| Component, wt.% | Olive cake (As received) |
| Moisture | 13,47 |
| Ash | 8 |
| C | 33,7 |
| H | 4,6 |
| O | 38,8 |
| N | 1,5 |
| S | 0,19 |
| LHV cal/kg | 3714 |
| HHV cal/kg | 4044 |

Table IV.2 Proximate Analysis of Olive Cake

| Proximate Analysis of Olive Cake | |
|----------------------------------|--------------------------|
| Component, wt.% | Olive cake (As received) |
| Moisture* | 13,47 |
| Ash* | 8 |
| Volatile Matter* | 66,39 |
| Fixed Carbon* | 12,14 |
| Ash** | 9,25 |
| Volatile Matter** | 76,72 |
| Fixed Carbon** | 14,02 |

*original base, ** dry base

IV. 2. 2. Stiochiometric Air Need for Combustion

Before doing this calculation we should define the system fuel feeding capacity. This is first assumption of the system and taken as 4kg/h.

I used the Eq. II.15 to find the stiochiometric air need. C,H,S,O and N values were taken from Table IV.1. We find the mass flow rates of the C,H,S,O and N by multiplying fuel flow rate by the element's mass fraction given by table IV.1.

$$C = 4 \text{ kg/h} \times 33,7/100 = 1,348 \text{ kg/h}$$

$$H = 4 \text{ kg/h} \times 4,6/100 = 0,184 \text{ kg/h}$$

$$S = 4 \text{ kg/h} \times 0,19/100 = 0,0076 \text{ kg/h}$$

$$O = 4 \text{ kg/h} \times 38,8/100 = 1,552 \text{ kg/h}$$

Putting this values into Eq. II.15

$$8,89 \times 1,348 + 26,7 \left(0,184 - \frac{1,552}{8} \right) + 3,340,0076 = 11,74 \text{ m}^3/\text{h} \text{ air for } 4 \text{ kg fuel,}$$

Which is $2,9 \text{ m}^3/\text{kg}$ fuel and $2,9 \text{ m}^3 \times 1,16 \text{ kg/m}^3 = 3,40 \text{ kg}$ air/kg fuel

IV. 2. 3. Selection of ER for Gasification

From the literature one can say most convenient ER for biomass gasification changes between 0.25-0.35. So I assumed the ER 0.3. The operation temperature of atmospheric fluidized beds is generally around 800°C - 900°C . I assumed the reactor

temperature will remain constant at 800°C. Air density and viscosity at 800°C are 0,338 kg/m³ and 5,68E-04 kg/ms respectively

The air need at the full capacity for the gasification with ER 0,3 is found by

$$\dot{m} = 3,41 \text{ kg/h} \times 0,3 = \mathbf{1,02 \text{ kg/h for 1 kg/h fuel}}$$

The volumetric air need is found by Eq. II.16

$$Q_{air} = \frac{1,02}{0,338} = 3,01 \text{ m}^3 \text{ air/kg fuel}$$

For 4kg/h feeding capacity the air flow rate inside the reactor should be

$$4 \times 3,01 = \mathbf{12,04 \text{ m}^3/\text{h}.(4,08\text{kg/h})}$$

IV. 2. 4. Fluidization velocity

Min fluidization velocity is found by Ergun equation (Eq. II.9), but first we should define the bed material characteristics and other parameters in the formula. The bed material was selected as silica sand. Unknown parameters of the Eq. II.8 and II.9 are given below

$$\varepsilon = \text{void fraction} = 0,4$$

$$\mu = \text{viscosity of the fluid} = 5,68\text{E-}04 \text{ kg/ms} (@825^\circ\text{C})$$

$$\phi = \text{Sphericity of the particle} = 1$$

$$d_p = \text{The average particle diameter} = 600 \text{ micron}$$

$$\rho_g = \text{Density of the fluid} = 0,338 \text{ kg/m}^3 (@825^\circ\text{C})$$

$$\rho_p = \text{Density of the particle} = 2500 \text{ kg/m}^3$$

Putting all the unknowns into the Eq II.8 and II.9 and solving second order equation we will get the min fluidization velocity as 0,016m/s

I took the operation velocity as 5,5 times the min fluidization velocity which is

$$5,5 \times 0,016 = \mathbf{0,64m/s}$$

IV. 2. 5. Reactor Cross Sectional Area and The Height

Reactor area is found by Eq. II.13

$$\frac{12,04m^3/h}{0,69m/sec} \frac{1h}{3600sec} = 53cm^2$$

Diameter of the reactor = **82mm**

Since this is not a standard pipe diameter closest standard pipe is selected as 3” (88,9mm/3,05mm) sch 10S. The operation temperature of the gasifier is 800 C. The reactor material is selected AISI 310 steel which can withstand that temperature.

The height was simply found by multiplying gas residence time by operation velocity. Gas residence time is the time required for the gas phases to reach the chemical equilibrium inside the reactor and usually taken between 2 and 4 sec. In our case residence time was taken as 3,2 sec.

Height= Residence time x operation velocity

$$3,2sec \times 0,69m/sec = \mathbf{2,2m}$$

IV. 3. DISTRIBUTOR PLATE DESIGN

We should assume the orifice diameter, pressure drop at the bed and pressure drop through the distributor plate. Orifice diameter was selected as 1,5 mm [26]. The pressure drop per unit length through the bed is found by Eq. II.8. We should find the bed height which is assumed as 0,8 times reactor diameter.

Putting al the values into Eq. II.14 and II.15

$$U_o = 0.8 \left[\frac{2 \times 482,78 \text{ pa}}{1,16 \text{ kg/m}^3} \right] = 23,08 \text{ m/s}$$

$$N = \frac{0.64 \text{ m/s} \times 0,338 \text{ kg/m}^3 \times 4}{23,08 \text{ m/s} \times 1,16 \text{ kg/m}^3 \times \pi \times 0,0015^2} = 0,45 \text{ hole/cm}^2$$

$$\text{Number of hole} = N \times \text{Area} \quad 0,45 \text{ hole/cm}^2 \times 53 \text{ cm}^2 \sim 24 \text{ hole}$$

I assumed the hole should be 1,2 times the calculated value to stay at the safe side of the design

$$\text{Number of hole}' = 24 \times 1,2 = 28,8$$

We used stand pipe type orifice plate to prevent the backflow of the sand. I assumed each stand pipe has four hole =>

$$28,8/4 = 7,2 \text{ stand pipe we chose the closest integer } \mathbf{\text{number of stand pipe is 8}}$$

IV.4. SCREW FEEDER DESIGN

The feeding system is a two stage screw feeder. One of them can be controlled to calibrate the feeding rate by changing the motor speed while the other one pushes the fuel into the reactor with a constant high speed. Considering manufacturing capabilities both screws are selected identical.

Below assumptions were done to design a screw feeder:

| | | | |
|---------------------------|---|---|-----------------------------------|
| Pitch diameter (Dp): 20mm | } | Restricted by manufacturing capabilities. | |
| Pitch (P): 20mm | | | |
| Shaft diameter (Ds): 10mm | | } | Restricted by motor and reductor. |
| RPM (N): 50 | | | |

F: Depends on fuel assumed to be 0.5 for olive cake [27]

The surface area of the screw pitch is found by:

$$A=(D_p^2-D_s^2) \pi/4 = 0.00165\text{m}^2$$

$$\text{Tan}(a)=P/ \pi D = 0,25$$

$$V_{te} = \pi DN/60 = 0,05\text{m/s}$$

$$V_a = V_{te} \text{tan}(a) = 0,017\text{m/s}$$

$$\text{Feeding capacity} = d A V_a f 3600 \quad (\text{II.16})$$

$$= 5,12\text{kg/h}$$

After designing the screw feeder it was manufactured at the machine shop. The screw was made at turning machine by machining the brass rod.

The designed screws were calibrated with olive cake. The calibration done by changing the first screw's motor frequency between 7 and 18 Hz. and fixing the second screw's motor speed at 250 RPM. At each frequency feeder was run for two minutes and fuel coming from the feeder collected and measured. The run for each frequency is repeated twice to ensure the result. The calibration results are shown in Table IV.3. The results show that the feeding of the fuel is very stable.

Table IV.3. Calibration Results of The Screw Feeder

| Motor 1 | Motor 2 | Time | Amount | Average Flow rate |
|---------|---------|------|--------|-------------------|
| RPM | Fr | min | gr | gr/min |
| 250 | 7 | 2 | 22,4 | 11,45 |
| 250 | 7 | 2 | 23,4 | |
| 250 | 9 | 2 | 28,6 | 14,45 |
| 250 | 9 | 2 | 29,2 | |
| 250 | 12 | 2 | 38,5 | 19,30 |
| 250 | 12 | 2 | 38,7 | |
| 250 | 14 | 2 | 45,3 | 22,65 |
| 250 | 14 | 2 | 45,3 | |
| 250 | 16 | 2 | 53,7 | 26,88 |
| 250 | 16 | 2 | 53,8 | |
| 250 | 18 | 2 | 63 | 31,48 |
| 250 | 18 | 2 | 62,9 | |

IV.5 CYCLONE DESIGN

According to design steps explained at section III.4. the gas flow rate should be found. It was found by mass balance.

Mass inlets are air and solid. Mass outlets are gas and ash.

$$\text{Total Mass in} = \text{Total mass out} ; \quad \dot{m}_{air} + \dot{m}_{fuel} = \dot{m}_{gas} + \dot{m}_{ash} \quad (\text{II.17})$$

$$4,08 + 4 \text{ kg} = \dot{m}_{gas} + 0,32 \text{ kg}$$

$$\dot{m}_{gas} = 7,76 \text{ kg/h}$$

At this point we have to assume a typical gas composition to determine the gas properties including gas density. We take the typical gas composition for olive cake gasification from the literature [21] (Table IV.4).

Table IV.4 Typical Biomass Gasification Gas Composition

| Gas Composition | %v/v |
|------------------------|-------|
| CO | 8.6 |
| CO ₂ | 21.7 |
| H ₂ | 5.4 |
| CH ₄ | 3 |
| N ₂ | 59.46 |
| Other HC | 1.84 |
| LHV MJ/Nm ³ | 3.8 |

We found the gas properties using HYSIS simulation program. We took the design temperature as 1000°C and design pressure as 100kPa Figure (IV.3)

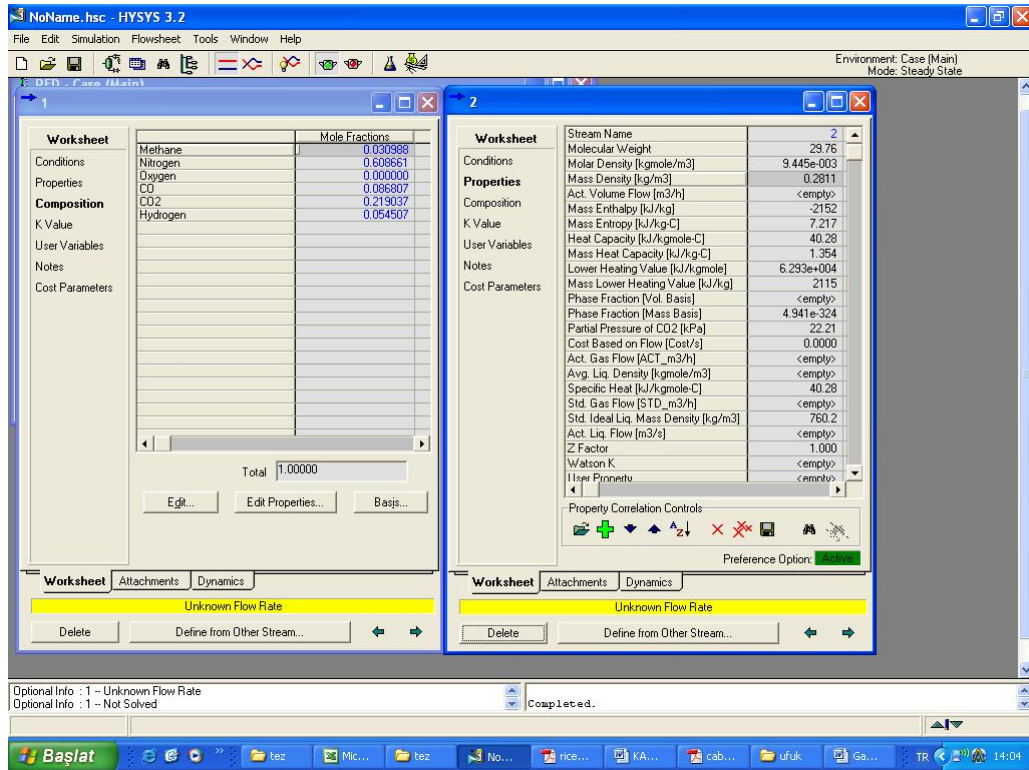

Figure IV.3 Gas properties for Typical Gas Composition HYSIS Screenshot

Gas density was calculated as $0,2811 \text{ kg/m}^3$

The gas flow rate inside the reactor was found by

$$Q_{\text{gas}} = \frac{\dot{m}_{\text{gas}}}{\rho_{\text{gas}}} \quad (\text{II.18})$$

$$\text{gas flow rate} = \frac{7,76}{0,2811} = 27,6 \text{ m}^3/\text{h}$$

The inlet are found by Eq. II.19

$$=55,38\text{mm}$$

Since it is impossible to find 55,38mm diameter pipe we took the Standard pipe, 2 1/2" sch 10S (76.1/3.07mm). Other cyclone dimensions were found by using Lapple cyclone coefficients from Figure III.3

IV.6 EXPERIMENTAL MATRIX

Two different fuels were tested on the system. One of them is biomass (olive cake) and the other one is coal (Orhaneli). Two main operating parameters that studied during experiments are the temperature and the ER. Table IV.5 shows the experimental matrix.

Table IV.5 The experimental matrix

| Fuel | ER | Temperature °C | |
|------------------|------|----------------|------|
| Olive Cake | 0.20 | 750 | |
| | | 800 | |
| | | 850 | |
| | | 900 | |
| | 0.30 | 750 | |
| | | 800 | |
| | | 850 | |
| | | 900 | |
| | 0.20 | 850 | |
| | | | 0.27 |
| 0.30 | | | |
| 0.35 | | | |
| | | | |
| Orhaneli Lignite | 0.25 | 850 | |
| | 0.30 | | |
| | 0.35 | | |
| | 0.40 | | |

IV.7 RESULTS OF OLIVE CAKE EXPERIMENTS

Tests were performed with olive cake. Particle size ranged from 1 to 2 mm. The moisture content of the fuel was measured as 13,21%. In Table IV.1 the chemical characterization of fuel was presented.

First set of experiments are described in Table IV.6. Based on the fuel analysis, it was determined the amount of air need, to ensure the fluidization of the sand bed (450 micron) and the gasification reactions. There for in order to maintain an ER of 0,2, using a fuel flow rate of 14,4 g/min and air flow rate of 9,8 g/min. With this amount of air 0,09m/s of air flow rate is reached inside the reactor which is 1,5Umf.

Table IV.6 Experiment Conditions And Results of Olive Cake Set 1

| Parameters | E1 | E2 | E3 | E4 |
|-------------------------------|-------|-------|-------|-------|
| T (C) | 750 | 800 | 850 | 900 |
| ER | 0,2 | 0,2 | 0,2 | 0,2 |
| Fuel feeding (g/min) | 14,4 | 14,4 | 14,4 | 14,4 |
| Air flow rate (l/min) | 8,45 | 8,45 | 8,45 | 8,45 |
| N ₂ purged (l/min) | 2,6 | 2,6 | 2,6 | 2,6 |
| U _{op} (m/s) | 0,09 | 0,09 | 0,09 | 0,09 |
| Volume Gas Comp % | | | | |
| CO | 17,13 | 17,42 | 16,60 | 14,53 |
| CO ₂ | 9,73 | 9,07 | 9,10 | 10,71 |
| CH ₄ | 3,51 | 3,51 | 3,54 | 3,69 |
| H ₂ | 5,83 | 6,41 | 7,23 | 10,46 |
| N ₂ | 60,81 | 60,52 | 60,06 | 57,52 |
| O ₂ | 2,99 | 3,07 | 3,46 | 3,09 |
| LHV (Mj/Nm ³) | 4,05 | 4,15 | 4,15 | 4,29 |

In Figure IV.4 it is present the effect of temperature increase on the gas composition and in Figure IV.5 effect of temperature increase on the lower heating value (LHV)

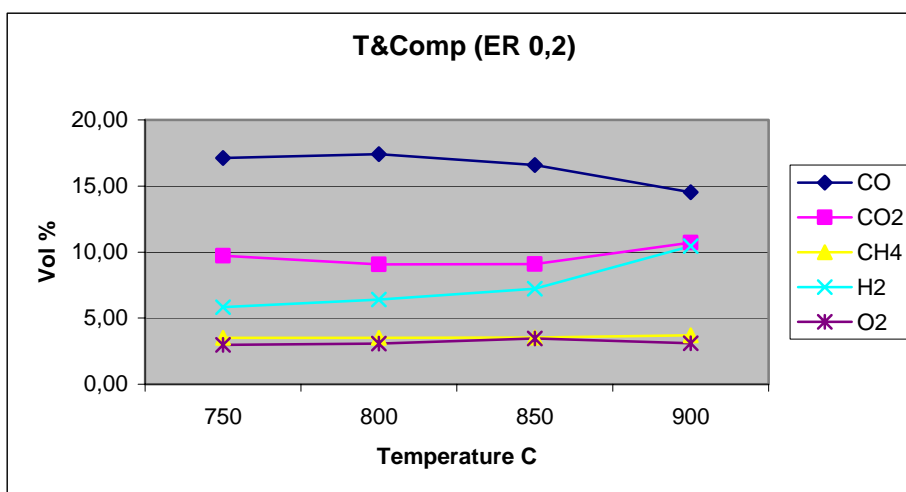
**Figure IV.4** Gas Composition & Temperature for For Olive Cake ER 0,2

In Figure IV.4 it can be observed that between the temperatures 750°C and 900°C, H₂ concentration is increasing with the temperature increase while CH₄ concentration stays almost constant. For temperature between 750°C and 850°C, temperature has little

effect on CO, CO₂, concentrations, but between 850°C and 900°C, CO concentration is decreasing with temperature increase. The O₂ concentration during experiment was always more than expected this is probably resulting of air leak.

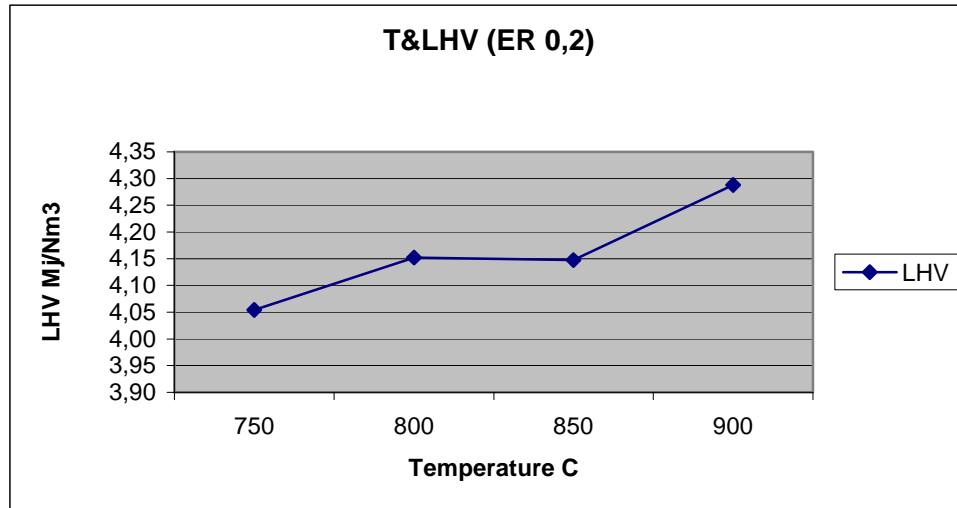

Figure IV. 5 LHV& Temperature For Olive Cake ER 0,2

In Figure IV.5 it can be seen that the rise of temperature has no effect on LHV between 800°C and 850°C while has increasing effect between 850°C and 900°C.

Second set of experiment are described in Table IV.7. In this set ER of 0,3 was kept constant and the effect of temperature was observed. This set is similar to previous.

Table IV.7 Experiment Conditions And Results of Olive Cake Set 2

| Parameters | E1 | E2 | E3 | E4 |
|---------------------|-------|-------|-------|-------|
| T (C) | 750 | 800 | 850 | 900 |
| ER | 0,3 | 0,3 | 0,3 | 0,3 |
| Fuel feeding g/min | 14,4 | 14,4 | 14,4 | 14,4 |
| Air flow rate l/min | 12,68 | 12,68 | 12,68 | 12,68 |
| N2 purged l/min | 0 | 0 | 0 | 0 |
| Uop (m/s) | 0,13 | 0,13 | 0,13 | 0,13 |
| Volume Gas Comp % | | | | |
| CO | 16,61 | 16,92 | 20,85 | 14,47 |
| CO ₂ | 12,43 | 12,44 | 11,91 | 14,00 |
| CH ₄ | 3,90 | 3,84 | 5,16 | 3,28 |
| H ₂ | 5,04 | 6,75 | 9,34 | 10,60 |
| N ₂ | 61,49 | 59,77 | 52,74 | 57,14 |
| O ₂ | 0,52 | 0,52 | 0,00 | 0,52 |
| LHV (Mj/Nm3) | 4,04 | 4,24 | 5,49 | 4,15 |

In Figure IV.6 it is present the effect of temperature increase on the gas composition and in Figure IV.7 effect of temperature increase on the lower heating value

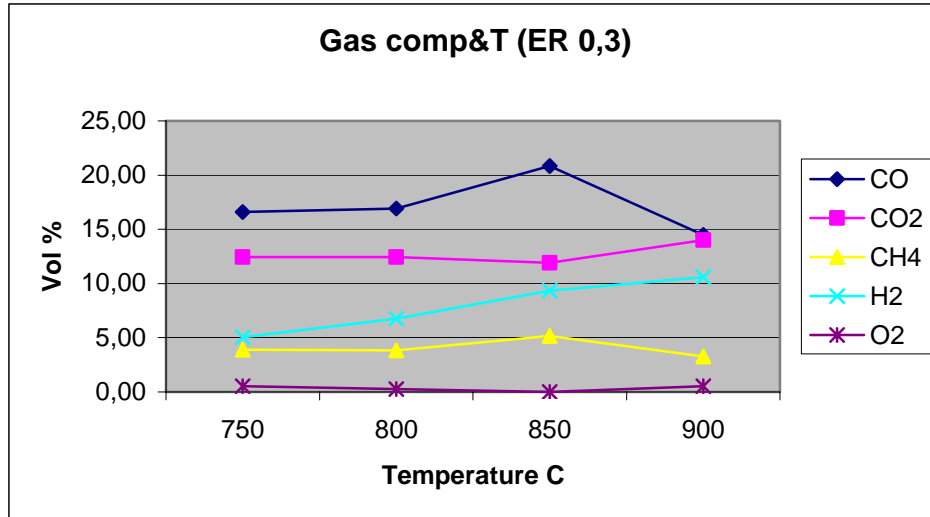

Figure IV.6 Gas Composition & Temperature for For Olive Cake ER 0,3

In the Figure IV.6 it can be seen that the temperature increase has almost no effect on gas composition between 750°C and 800°C. Between 800°C and 850°C temperature increase has increasing effect on CO, CH₄ and H₂ while it has decreasing effect on CO₂ concentration. Between 850°C and 900°C CO and CH₄ concentrations are decreasing while CO₂ and H₂ concentrations are increasing. After first of experiment possible leak points were examined and found on gas cleaning system. After necessary modifications against leak, O₂ Concentration is maintained at almost zero during all experiments.

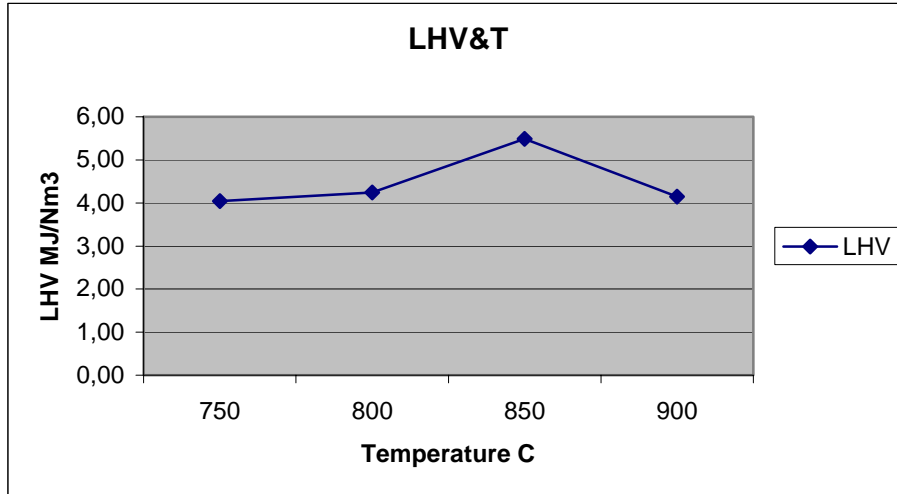

Figure IV.7 LHV& Temperature For Olive Cake ER 0,3

Figure IV.7 shows that the LHV show great increase between 800 °C and 850°C and the highest value at 850°C. At other temperature intervals the LHV of the gas compositions remains almost same

Last set of experiments described in Table IV.8. From the previous set the highest LHV was observed at 850°C, so at this set, temperature kept constant at 850°C and ER were changed between 0,2 and 0,35 to obtain the best operating conditions.

Table IV.8 Experiment Conditions And Results of Olive Cake Set 3

| Parameters | E1 | E2 | E3 | E4 |
|---------------------------|-------|-------|-------|-------|
| T (C) | 850 | 850 | 850 | 850 |
| ER | 0,2 | 0,27 | 0,3 | 0,35 |
| Fuel feeding g/min | 14,4 | 14,4 | 14,4 | 14,4 |
| Air flow rate l/min | 8,85 | 11,4 | 12,68 | 14,76 |
| N2 purged l/min | 2,6 | 0 | 0 | 0 |
| Uop (m/s) | 0,09 | 0,12 | 0,13 | 0,15 |
| Volume Gas Comp % | | | | |
| CO | 16,6 | 17,64 | 20,85 | 18,12 |
| CO ₂ | 9,1 | 11,36 | 11,91 | 12,23 |
| CH ₄ | 3,54 | 4,22 | 5,16 | 3,99 |
| H ₂ | 7,23 | 9,58 | 9,34 | 7,69 |
| N ₂ | 60,07 | 56,47 | 52,74 | 57,97 |
| O ₂ | 3,46 | 0,73 | 0 | 0 |
| LHV (Mj/Nm ³) | 4,15 | 4,77 | 5,49 | 4,55 |

In Figure IV.8 it is shown the effect of temperature increase on the gas composition and in Figure IV.9 effect of temperature increase on the lower heating value (LHV)

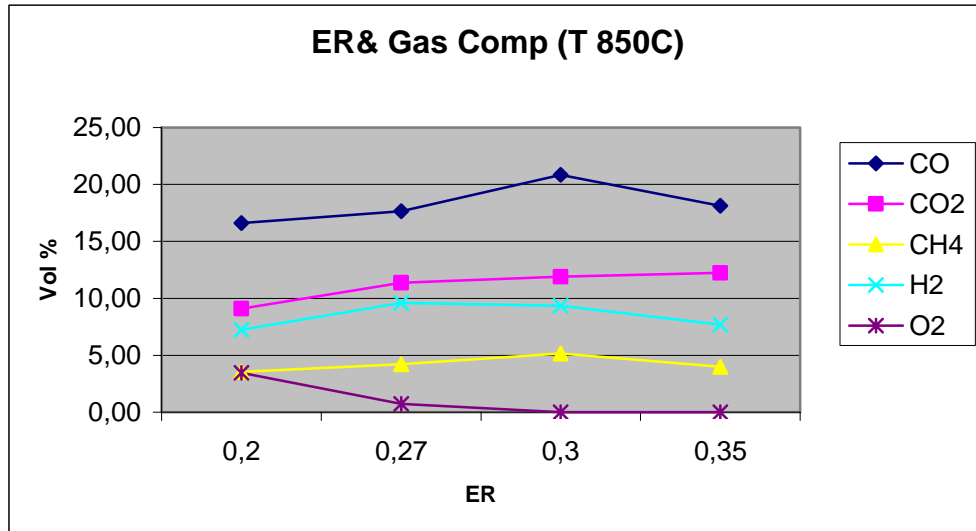

Figure IV.8 Gas Composition & ER For Olive Cake T 850°C

From the Figure IV.8 it can be easily seen that all the gas concentrations are increasing between ER 0,2 and 0,27. Whereas between ERs 0,27 and 0,3, CO₂, CH₄ and H₂ concentrations shows slight movements while CO concentration still increases. Between ERs 0,3 and 0,35 CO₂ concentration increases while all other concentrations decrease. Figure IV.9 shows that the highest LHV is reached at ER 0,3.

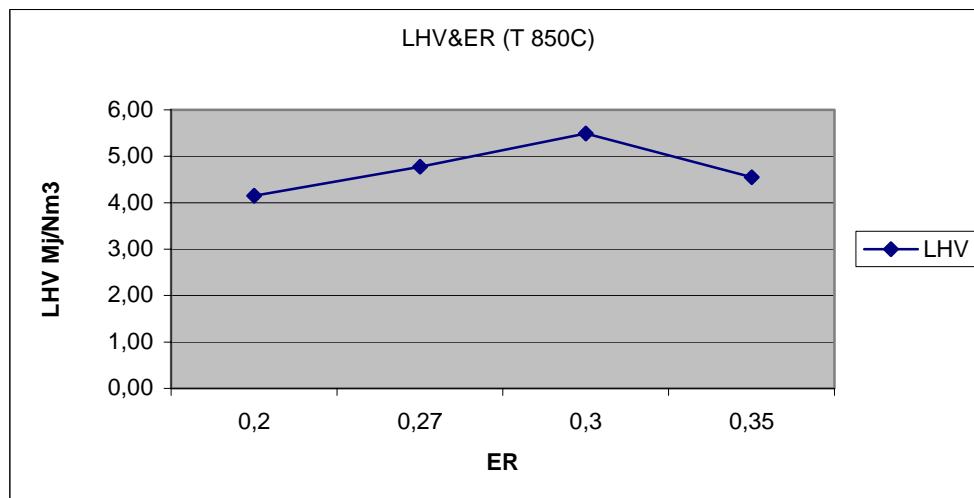

Figure IV.9 LHV& ER For Olive Cake T 850°C

These results can be compared to the results of different authors and trends seem to be consistent to what could be expected in terms of temperature effect on the syngas composition and on LHV. Another interesting result, which also agrees to what could be expected, is the decrease of char production as temperature was increased due to its consumption in the gasifier. By looking this results one can easily say that the best operating conditions for olive cake gasification is reached at 850°C temperature and 0,3 ER.

The problems were occurred during experiments are

- Bed agglomeration
- Back flow of the syngas
- Blocking of the screw feeder

IV. 8. RESULTS OF ORHANELI COAL EXPERIMENTS

After Olive cake Orhaneli coal was used. Particle size of Orhaneli Coal ranged from 1 to 2mm, the moisture content was %27,5. In Table IV.9 and IV.10 chemical analysis of the fuel used is presented. In the experiment the temperature kept constant at 850°C and effect of ER was observed. ER were changed between 0,25 and 0,40. Only one experiment was performed for Orhaneli coal. At the beginning ER was set to 0,25 when steady state conditions reached, gas composition were noted for 10 minutes, then ER is switched to

Table IV.9 Proximate Analysis of Orhaneli Coal

| Proximate Analysis of Orhaneli Coal | |
|-------------------------------------|--------------------------|
| Component, wt.% | Olive cake (As recieved) |
| Moisture* | 27,5 |
| Ash* | 32,5 |
| Volatile Matter* | 27,89 |
| Fixed Carbon* | 12,08 |
| Ash** | 44,87 |
| Volatile Matter** | 38,47 |
| Fixed Carbon** | 16,66 |

*original base, ** dry base

Table IV.10 Ultimate Analysis of Orhaneli Coal

| Ultimate Analysis of Orhaneli Coal | |
|------------------------------------|--------------------------|
| Component, wt.% | Olive cake (As recieved) |
| Moisture | 27,5 |
| Ash | 32,5 |
| C | 23,3 |
| H | 2,4 |
| O | 11,5 |
| N | 0,8 |
| S | 1,9 |

0,3. Same procedure was applied for all other ERs. The operating Conditions of the Experiment are given in Table IV.11.

Table IV.11 Experiment Conditions And Results of Orhaneli Coal

| Parameters | E1 | E2 | E3 | E4 |
|------------------------------|-------|-------|-------|-------|
| T (C) | 850 | 850 | 850 | 850 |
| ER | 0,25 | 0,3 | 0,35 | 0,40 |
| Fuel feeding g/min | 19,3 | 19,3 | 19,3 | 19,3 |
| Air flow rate l/min | 9,23 | 11,08 | 12,93 | 14,77 |
| N2 purged l/min | 0 | 0 | 0 | 0 |
| Uop (m/s) | 0,098 | 0,117 | 0,137 | 0,157 |
| Volume Gas Comp % | | | | |
| CO | 14,69 | 15,99 | 19,71 | 27,00 |
| CO ₂ | 14,25 | 13,00 | 11,47 | 2,21 |
| CH ₄ | 4,15 | 4,38 | 4,18 | 1,16 |
| H ₂ | 26,01 | 24,61 | 24,77 | 12,52 |
| N ₂ | 40,50 | 41,38 | 39,43 | 56,42 |
| O ₂ | 0,40 | 0,64 | 0,46 | 0,69 |
| Gas Yield kg/Nm ³ | 0,93 | 1,10 | 1,34 | 1,07 |
| LHV (Mj/Nm ³) | 6,15 | 6,25 | 6,66 | 5,18 |

Figure IV.10 shows the effect of ER change on the gas composition while Figure IV.11 shows the effect of ER change on the lower heating value (LHV). Figure IV.12 shows the effect of ER change on gas yield. Gas yield was defined as amount of gas produced per kg fuel (Nm³/kgfuel).

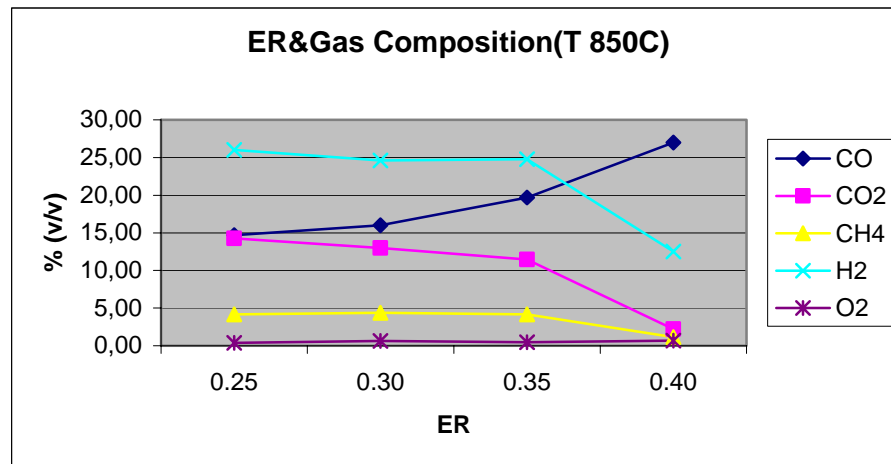
**Figure IV.10** ER & Gas Composition For Orhaneli Coal T 850°C

In Figure IV.10 it can be seen that the increase of ER from 0,25 to 0,30 have led to reduction of H₂, CO₂ and increase of CO, CH₄. Further increase of ER from 0,30 to 0,35 have led to reduction of CO₂, CH₄ and increase of CO. H₂ remained almost constant.

Finally when ER changed between 0,35 and 0,40, all of the gases are decreasing but CO increasing.

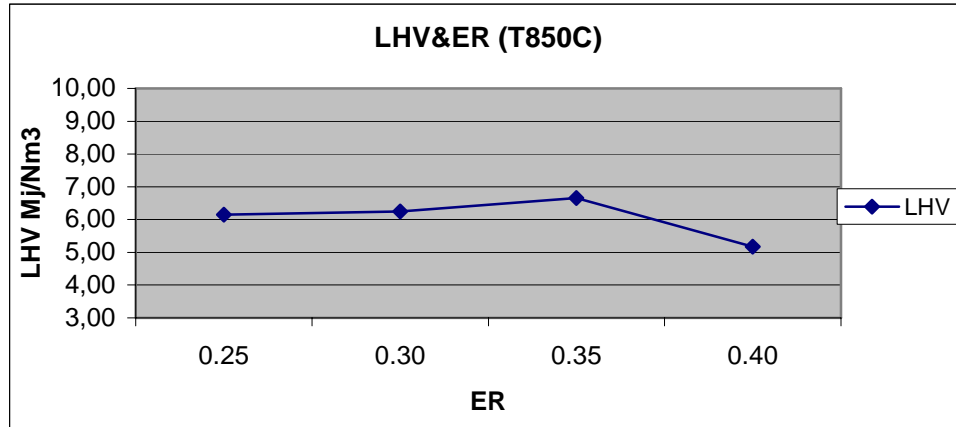

Figure IV.11 ER& LHV For Orhaneli Coal T 850°C

Figure IV.11 shows that LHV increasing between ER 0,25 and 0,35 reaches the max value at ER 0,35. Further increase of ER has led to decrease of LHV. In Figure IV.12 it can be seen that gas yield graph shows the similar trend as LHV as expected, and reaches the max value at ER 0,35.

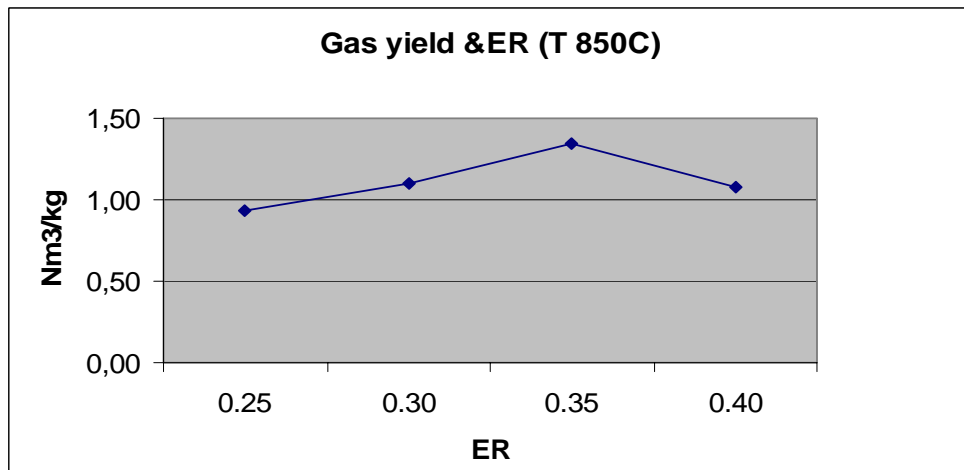

Figure IV.12 Gas Yield& ER

The results of experiments are comparable with the literature. Trends are as expected. Looking these results one can say the optimum operating condition for Orhaneli Coal is reached at 850 °C temperature and 0,35 ER.

V. CONCLUDING REMARKS AND SUGGESTIONS

The preliminary experiments just prove our BFBG operates well, and the results generally follow the data in the literature. We reached the typical gas calorific value around 4-6 MJ/Nm³ for both olive cake and Orhaneli coal. We showed that the gasification of Turkish lignite and biomass is one of the useful ways of utilizing them. Our study was based on the built up the lab infrastructure for gasification. Before building industrial scale gasifiers for Turkish lignite and biomass, further studies on the system should be done.

Some suggestions for system operation are given below

- a. For safety issues electrical connections must be checked and the support structure should be improved enabling easy access to the system and its components.
- b. Gas lines should be checked regularly to prevent blockages.
- c. Diameter of the gas lines may be increased for smaller pressure drops which prevents the backflow of the gas from the fuel silo.
- d. Insulation of the system especially cyclone and the gas line insulation must be improved. Poor insulation on the line results the condensing tar and blockage of the lines.
- e. Calibration of the flow meters, pressure and temperature transmitters should be done regularly.
- f. The moisture content of the feed air should be controlled by measuring it or capturing all the moisture.

Suggestions for further studies are given below;

- a. Secondary air may be introduced to the system and the effect of secondary air injection may be studied.
- b. Different distributor plate designs may be tried and its effect can be observed

- c. Different types and different diameters of bed materials and can be tried for hydrodynamic studies.
- d. Steam may be injected for steam gasification application.
- e. Mixture of coal and biomass can be gasified.
- f. Tar analysis may be performed and effect of operating parameters on Tar production may be studied.

The installation of a gasification system, or any other system, is not an end on itself but a beginning. Independently of the type of work carried out in the gasifier, it must be done methodically and with discipline, so the data and the information collected can be reliable, being this assumption valid for engineering and/or for scientific work. As a final remark it must be pointed out that the results obtained are only indicative ones, specially if it is taken into account that these are the first results, originated by an installation not yet fully optimised and “understood”, and that during the all the period of the tests, adjustments were made in order to know what was the impact of that changes in the obtained results.

REFERENCES

- [1] Prof. Dr. Hüsnü Atakül's Presentation Bigpower Seminar I, "An Overview of Energy Resources of Turkey" (2006)
- [2] Assoc. Prof. Dr. Hayati Olgun's Presentation Turkish-American clean energy Conference (2008)
- [3] Nicholas, P.; Cheremisinoff.; Rezaian, J.: *Gasification Technologies A Primer for Engineers And Scientists*, Taylor & Francis, USA (2005)
- [4] Basu, P.: "Combustion and Gasification in Fluidized Beds", CRC Press, Taylor & Francis Group, USA, (2006)
- [5] Kovacik et al.: "Equilibrium Calculations in Coal Gasification" *Hydrogen Energy* (1989)
- [6] Murakami et al.: "Some process fundamentals of biomass gasification in dual fluidized bed" , *Fuel* (2006)
- [7] Cao, Y. et al.: "A novel biomass air gasification process for producing tar free higher heating value fuel gas" *Fuel Processing Technology* 87, (2006), 343-353
- [8] www.gasification.org
- [9] Quaser, S. A.: "Natural gas substitutes from coal and oil", *Coal Sci. Techno. Vol 8* (1985)

- [10] Petersen, I.; Werther, J.: “Experimental investigation and modeling of gasification of sewage sludge in the circulating fluidized bed” *Chemical Engineering and Processing October 44 (2004) 717-736*
- [11] Li, T.X. et. al.: “Biomass gasification in a circulating fluidized bed” *Biomass and Energy 26 (2004) 171-193*
- [12] McKendry P.: “Energy production from biomass (part 3): *Gasification Technologies Biosource Technology (2001)*
- [13] G.G Brown et al.: *Unit Operations*, Jhon Wiley and Sons, New York, (1950)
- [14] www.engin.umich.edu
- [15] Ergun, S., “Fluid flow through packed columns”, *Shem, Eng. Prog.*, 48, 89-94, (1952)
- [16] <http://en.wikipedia.org/>
- [17] Onat, K.; Genceli Osman, F.; i, Arisoy, A.: *Buhar kazanlarının ısı hesapları*, İstanbul, İTÜ, (1969)
- [18] Bortolamasi, M; Fottner, J.: *Design And Sizing Of Screw Feeders* International Congress for Particle Technology (2001)
- [19] Perry Robert, H.; Gren W, D.: *Perry’s Chemical Engineers’ Handbook* Mc Graw Hill, (1999) 17-27
- [20] *Clean 2008*, 36 (3), 315 – 319
- [21] <http://www.gasification.net/>

[22] <http://www.fossil.energy.gov/>

[23] <http://www.fao.org>

[24] Warnecke R, “Gasification of biomass: comparison of fixed bed and fluidized bed gasifier” Biomass and Energy January 2000

[25] www.em-ea.org

[26] Zenz, F. A. Weil, N. A., A theoretical-empirical approach to mechanism of particle entrainment from fluidized beds. *AICE J.*, 4, 472, **1958**.

[27] Personal interview with Prof. Dr İbrahim Gülyurtlu

[28] Personal interview with Jose Maria Sanchez

[29] <http://www.cogeneration.net/Coal-Gasification.htm>

APPENDIX

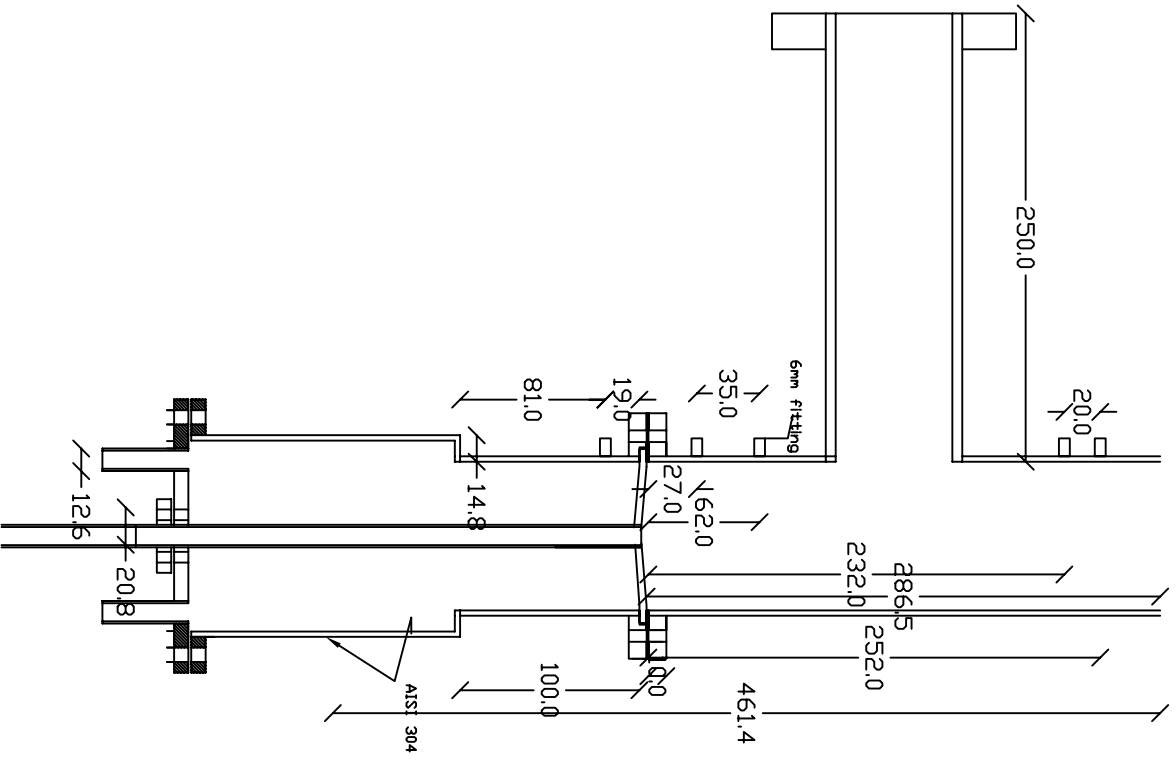

| | |
|---------------------------|--------------|
| NAME | Ufuk Kayhan |
| DRAWN | |
| CHECKED | |
| ENG APPR | |
| MGR APPR | |
| TITLE | APPENDIX A-2 |
| LOWER SECTION OF GASIFIER | |
| SIZE/DWG NO | A4 / 2 |
| REV | |

| | | |
|--------|---------|--------------|
| SCALE: | WEIGHT: | SHEET 1 OF 1 |
|--------|---------|--------------|

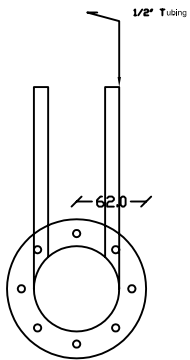
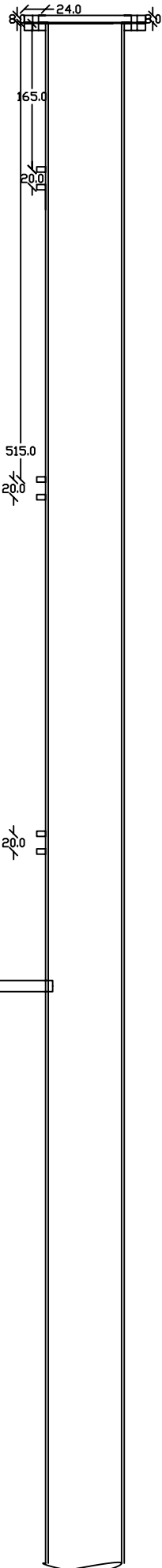

| | | | |
|----------|--------------|---------------------------|--------------|
| | NAME | APPENDIX A-3 | |
| DRAWN | Ufuk Kayahan | | |
| CHECKED | | TITLE | |
| ENG APPR | | UPPER SECTION OF GASIFIER | |
| MGR APPR | | SIZE/DWG NO | REV |
| | | A4 3 | |
| | SCALE: | WEIGHT: | SHEET 1 OF 1 |

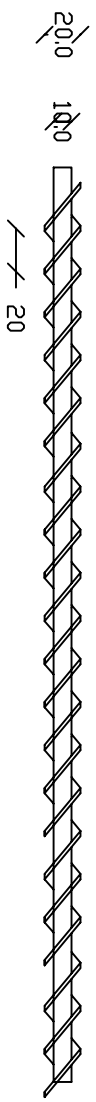
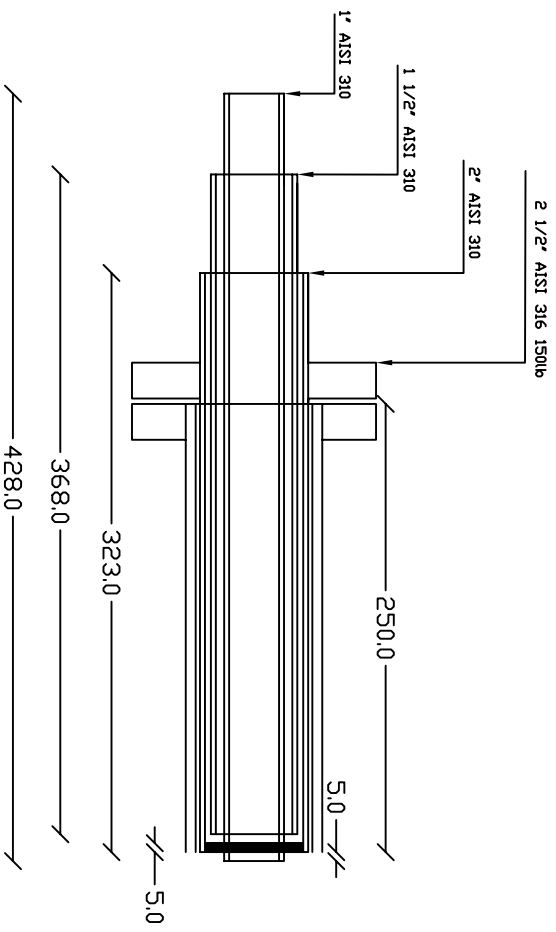

| | |
|----------|-----------------------|
| NAME | Ufuk Kayahan |
| DRAWN | |
| CHECKED | |
| ENG APPR | |
| MGR APPR | |
| TITLE | APPENDIX A-4 |
| | Feeding Point & Screw |
| SIZE | A4 |
| DWG NO | 4 |
| REV | |

| | | |
|--------|---------|--------------|
| SCALE: | WEIGHT: | SHEET 1 OF 1 |
|--------|---------|--------------|

CURRICULUM VITAE

Ufuk Kayahan was born in İstanbul in 1982. He completed his high school study in Şehremini Lisesi, he started intensive English program in Language School of Marmara University for one year. Then he started mechanical engineering program at Engineering Faculty of Marmara University. After he graduated from mechanical engineering department in 2005 he was approved of Master of Science degree for mechanical engineering at Marmara University. He also started to work in TUBITAK Marmara Research Center Energy Institute as a Researcher. His research areas are combustion and gasification of coal and biomass.

MARMARA UNIVERSITY
THE INSTITUTE FOR
GRADUATE STUDIES IN PURE AND APPLIED SCIENCES

ACCEPTANCE AND APPROVAL DOCUMENT

The jury established by the Executive Board of the *INSTITUTE FOR GRADUATE STUDIES IN PURE AND APPLIED SCIENCES* on ^{07.07.2008} (Resolution no:.....) has accepted Mr ^{2008/17-66} UFUK KAYAHAN 's thesis titled "**DESIGN AND OEPRATION OF A LABORATORY SCALE FLUIDIZED BED GASIFICATION SYSTEM**" as Master of Science in Mechanical Engineering

Advisor : Prof. Dr. Z. Sibel ÖZDOĞAN, Marmara Üniversitesi

1. Member of the jury: Yrd. Doç Dr. Ebru MANÇUHAN, Marmara Üniversitesi

2. Member of the jury: Doç.Dr. Fehmi AKGÜN, TUBİTAK- MAM, Enerji Enstitüsü

Date : 13/08/2008

APPROVAL

Mr/Ms. UFUK KAYAHAN..... has satisfactorily completed the requirements for the degree of Master of Science / ~~Doctor of Philosophy~~ in Mechanical Engineering at Marmara University. The Executive Committee approves that he/she be granted the degree of Master of Science / Doctor of Philosophy on..... (Resolution no: ^{08.08.2008} ^{2008/23-2})

DIRECTOR OF THE INSTITUTE

Prof. Dr. Sevil ÜNAL
Müdür.
